



# IECC 2018

nLight® Applications Guide





## / nLight Lighting Controls Platform

---

### **It's not just smarter. It's easier.**

nLight is a digital lighting controls solution that offers wired and wireless lighting controls that easily connect luminaires, sensors, and other control devices to create a digital network.

The nLight platform of products enables ease in specification, installation, and ownership, making it the go-to digital lighting controls platform for specifiers, contractors, and building owners.



## / TABLE OF CONTENTS

---

- 04 Code Requirements for Common Building Spaces
- 05 How to Use This Guide
- 06 Enclosed Office Solutions
- 08 Open Plan Office Solutions
- 10 Conference Room Solutions
- 12 Classroom Solutions
- 14 Lobby Solutions
- 16 Corridor Solutions
- 18 Restroom Solutions
- 21 Stairwell Solutions
- 22 Warehouse Storage Solutions
- 23 Gymnasium Solutions
- 24 Parking Garage
- 25 Site Lighting
- 26 nLight Hybrid Networked Lighting Control
- 27 Requirements Overview
- 28 Emergency Lighting
- 29 Luminaires with Networked Embedded Controls from nLight



## / ABOUT

---

### **About IECC 2018**

The International Energy Conservation Code (IECC) 2018 is a residential and commercial building energy code. The IECC has been adopted by many states and municipalities. The intention of this code is to reduce energy consumption by outlining design and construction requirements which include specific constraints for lighting controls. The use of lighting controls to synchronize light levels with daylight, occupancy, and scheduled/manual inputs are required in order to be compliant.

### **About This Guide**

Acuity Brands® offers the nLight® IECC Applications Guide as a reference of typical nLight layouts that help make code compliance quicker and easier. The Acuity Brands Design Services Team is also available to support engineers and contractors with detailed design, submittal, and installation. For additional information, please contact your Acuity Brands Sales Representative.

### **About nLight**

nLight® is a sensor-based digital lighting controls solution that offers wired and wireless lighting controls that easily connect luminaires, sensors, and other control devices to create one digital lighting controls platform to aid in code compliance, reduce energy, and enable advanced networked capabilities. Ideal for practically any application, small to large, indoor to outdoor, nLight offers lighting controls that scale from one room to an entire floor, from one floor to an entire building, from one building to an entire campus.

The chart below is an overview of the Code Requirements for Common Building Spaces. Please use this information as a guide. For specific code requirements please refer to the IECC code.

	Control Requirement*	Code Provision	Code Summary*	Space Type										
				Enclosed Office	Open Plan Office	Conference, Meeting, Multipurpose Room	Classroom, Lecture Hall, Training Room	Lobby	Corridor	Public Restroom	Private Restroom	Non-Exit Stairwell	Gymnasium	
On-Off Control	Manual-On or Auto-On ≤ 50%	C405.2.1.1.1	Automatically controlled spaces must be controlled to automatically turn the lighting on to not more than 50% power.	✓		✓	✓							
	Full Automatic-On	C405.2.1.1.2	Automatically controlled spaces are allowed to turn on to full.					✓	✓	✓	✓	✓		
	Auto-Off ≤ 50%	C405.2.1.2	Occupancy sensors shall automatically reduce lighting in warehouse storage aisle-ways and open areas by ≤ 50%											
	Full Auto-Off via Occupancy Sensor	C405.2.1.1.1 & C405.2.1.3	Fixtures must automatically turn off within 20 minutes of all occupants leaving the space.	✓	✓	✓	✓	(or)	(or)	✓	✓	✓	✓	✓
	Time-Switch Controls (via System Controller)	C405.2.2.1	Each area of the building not provided with occupant sensor controls shall be provided with time switch controls. These areas must also be provided with a manual override switch.							✓	✓			✓
	Light Reduction Controls	C405.2.2.2	Spaces shall have a manual control that allows the occupant to reduce the connected lighting load uniformly by not less than 50%.		✓								✓	✓
	Manual Control (Local Switch)	C405.2.5	Areas shall incorporate a manual control to allow occupants to turn fixtures off.	✓	✓	✓	✓	✓	✓	✓	✓**	✓**	✓**	✓**
					(or)							(or)	(or)	
Daylight Control	Daylight-Responsive Controls	C405.2.3.1 & C405.2.3.2	Daylight-responsive controls shall be provided within each space with sidelight and toplight daylight zones totaling > 150W.	✓	✓	✓	✓	✓	✓	✓	✓	✓	✓	
Exterior Control	Exterior Lighting Controls	C405.2.6	C405.2.6.1 Daylight shutoff C405.2.6.2 Decorative lighting shutoff C405.2.6.3 Lighting setback C405.2.6.4 Exterior time-switch control function											

Notes:  
 \*This summary is for general information purposes only and is provided without any warranty as to accuracy, completeness, or otherwise. The user should read the applicable code sections for more complete and detailed descriptions of code requirements and exceptions and should consult with a professional engineer or other competent advisor before making any decision or taking any action based on this summary.  
 \*\* While energy code is required, safety may preclude the use of a manual controls in these spaces.

Warehouse	Parking Garage	Site Lighting
✓		
✓		
(or)		
✓		
✓		
	✓	✓

For each space type there will be a wired solution on the left and wireless solution on the right.

Room description: ENCLOSED OFFICE: < 250 sq. ft., Windows, Luminaires with Networked Embedded Controls from nLight

Room layout diagram with controls, fixtures, and wiring

Wire type legend

Required list of devices in order to implement room layout design above

Operational details describe the functionality provided by the equipment specified in the solution

Additional options that add control capacity beyond code requirements

**Wired**

**Wireless**

**Wire type legend**

- CAT-5e Cable
- Line Voltage Wires
- Line Power Feed

**Bill of Materials**

Symbol	Qty	Product #	Description
[Troffer Symbol]	2	See Note	Troffer with Wired Networked Embedded Controls from nLight
[Sensor Symbol]	1	nWSXA PDT LV DX	Wall Switch Occupancy Sensor with On/OFF, Raise/Lower

**Bill of Materials**

Symbol	Qty	Product #	Description
[Troffer Symbol]	2	See Note	Troffer with Wireless Networked Embedded Controls from nLight with Sensor Option
[Power Pack Symbol]	1	rPODBA DX G2	Battery Powered, On/OFF, Raise/Lower, Wall/Floor

**OPERATIONAL DETAILS:**

**Light Fixtures:**

- All fixtures are dimmable
- All fixtures can be controlled together or independently
- Maximum level can be task tuned to any percentage via programming

**Occupancy Control:**

- Fixtures must be turned on manually (or optionally can be configured to come on automatically to 50%)
- Fixtures turn off automatically when room becomes vacant

**Daylight Control:**

- Not required for offices without windows or that have loads <150W in sidelit zones

**Manual Control:**

- On/off / raise/lower control of fixtures

**ADDITIONAL OPTIONS:**

- Room can be connected to nLight backbone to enable network control or time schedules (C405.2.2.1 - Time-Switch Control), and also qualify for Enhanced Digital Lighting Controls (C405.4)
- HVAC control available through system-wide BACnet® interface option on the ECLYPSE® controller
- Luminaires with wireless networked embedded controls from nLight and occupancy/daylighting sensor options available, please see the fixture specification sheet
- nLight wired or wireless networked control devices address the monitoring and configuration requirements of Luminaire Level Lighting Controls (LLLC) (C405.2.1, C405.2.4, C405.2.5)
- For emergency lighting control use a power pack with ER/EM option or luminaire with networked embedded controls from nLight with emergency option

Note: Contact your local lighting agent for more information on luminaires with networked embedded controls from nLight. nLight wired or wireless networked control devices address the requirements of Luminaire Level Lighting Controls (LLLC), as specified in the IECC 2018 CODE.

www.nlightcontrols.com • 800-535-2465

## Wired

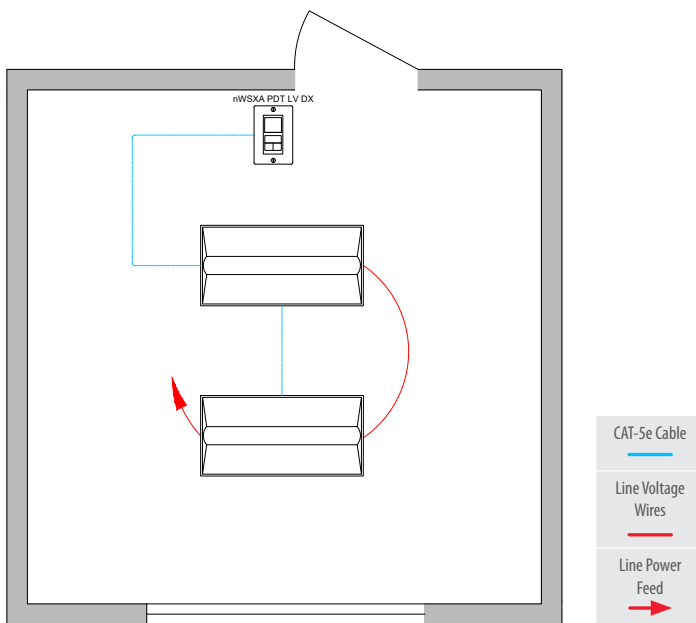

CAT-5e Cable

Line Voltage Wires

Line Power Feed

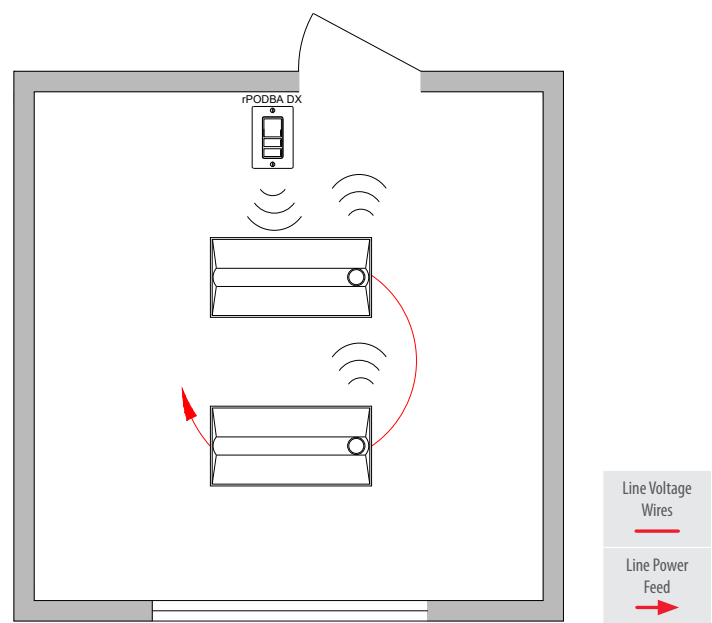

## Wireless





Line Voltage Wires

Line Power Feed

## Bill of Materials

Symbol	Qty	Product #	Description
	2	See Note	Troffer with Wired Networked Embedded Controls from nLight
	1	nWSXA PDT LV DX	Wall Switch Occupancy Sensor with On/Off, Raise/Lower

## Bill of Materials

Symbol	Qty	Product #	Description
	2	See Note	Troffer with Wireless Networked Embedded Controls from nLight with Sensor Option
	1	rPODBA DX G2	Battery Powered, On/Off, Raise/Lower WallPod®

## / OPERATIONAL DETAILS:

## Light Fixtures:

- All fixtures are dimmable
- All fixtures can be controlled together or independently
- Maximum level can be task tuned to any percentage via programming

## Occupancy Control:

- Fixtures must be turned on manually (or optionally can be configured to come on automatically to 50%)
- Fixtures turn off automatically when room becomes vacant

## Daylight Control:

- Not required for offices without windows or that have loads <150W in sidelit zones

## Manual Control:

- On/off & raise/lower control of fixtures

## / ADDITIONAL OPTIONS:

- Room can be connected to nLight backbone to enable network control or time schedules (C405.2.2.1 - Time-Switch Controls), and also qualify for Enhanced Digital Lighting Controls (C406.4)
- HVAC control available through system-wide BACnet® interface option on the ECLYPSE® controller
- Luminaires with wireless networked embedded controls from nLight with occupancy/daylighting sensor options available, please see the fixture specification sheet
- nLight wired or wireless networked control devices address the monitoring and configuration requirements of Luminaire Level Lighting Controls (LLLC) (C405.2.1, C405.2.4, C405.2.5)
- For emergency lighting control use a power pack with ER/EM option or luminaire with networked embedded controls from nLight with emergency option

**Note: Contact your local lighting agent for more information on luminaires with networked embedded controls from nLight. nLight wired or wireless networked control devices address the requirements of Luminaire Level Lighting Controls (LLLC), as specified in the IECC 2018 CODE.**



**Wired**

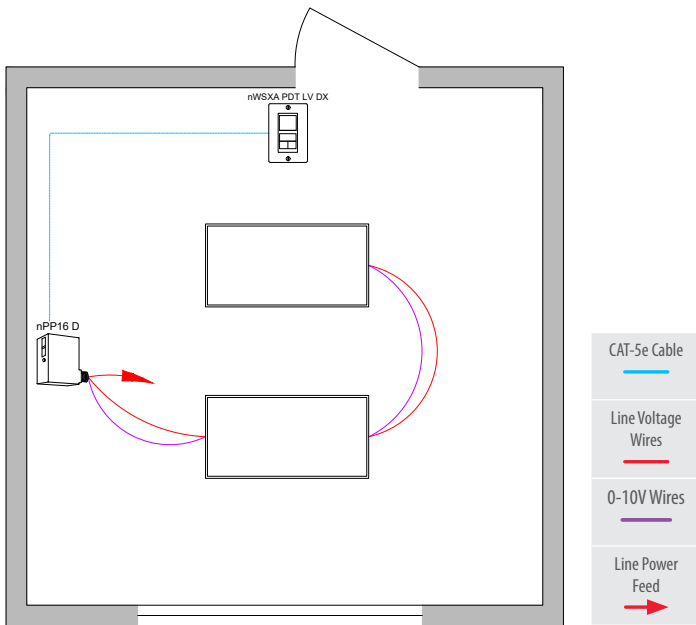

**Wireless**

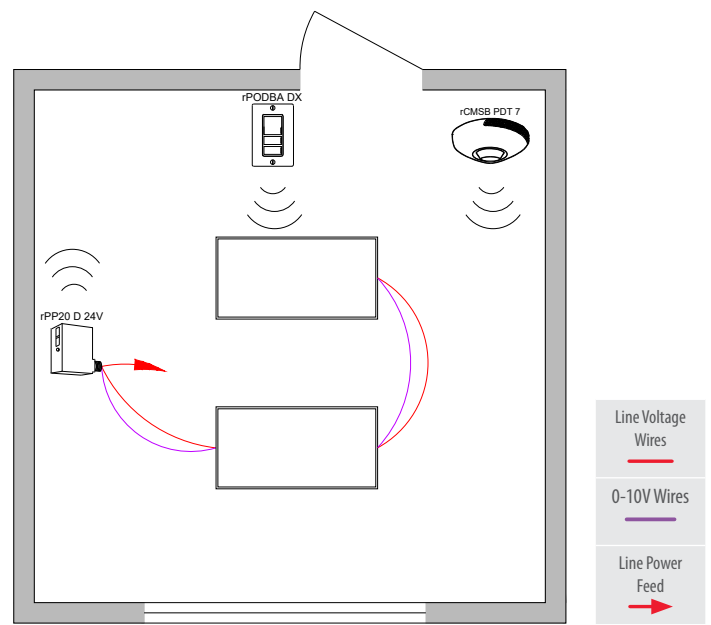

**Bill of Materials**

Symbol	Qty	Product #	Description
	1	nPP16 D EFP	Relay Pack with 0-10V Dimming Output
	1	nWSXA PDT LV DX	Wall Switch Occupancy Sensor with On/Off, Raise/Lower

**Bill of Materials**

Symbol	Qty	Product #	Description
	1	rPP20 D 24V EFP G2	Relay Pack with 0-10V Dimming Output
	1	rPODBA DX G2	Battery Powered, On/Off, Raise/Lower WallPod
	1	rCMSB PDT 7 G2	Battery Powered Occupancy Sensor

**OPERATIONAL DETAILS:**

**Light Fixtures:**

- All fixtures are dimmable
- All fixtures are controlled together
- Maximum level can be task tuned to any percentage via programming

**Occupancy Control:**

- Fixtures must be turned on manually (or optionally can be configured to come on automatically to 50%)
- Fixtures turn off automatically when room becomes vacant

**Daylight Control:**

- Not required for offices without windows or that have loads <150W in sidelit zone

**Manual Control:**

- On/off & raise/lower control of fixtures

**ADDITIONAL OPTIONS:**

- Room can be connected to nLight backbone to enable network control or time schedules (C405.2.2.1 - Time-Switch Controls), and also qualify for Enhanced Digital Lighting Controls (C406.4)
- HVAC control available through system-wide BACnet® interface option on the ECLYPSE® controller
- For emergency lighting control use a power pack with ER/EM option or luminaire with networked embedded controls from nLight with emergency option

## Wired

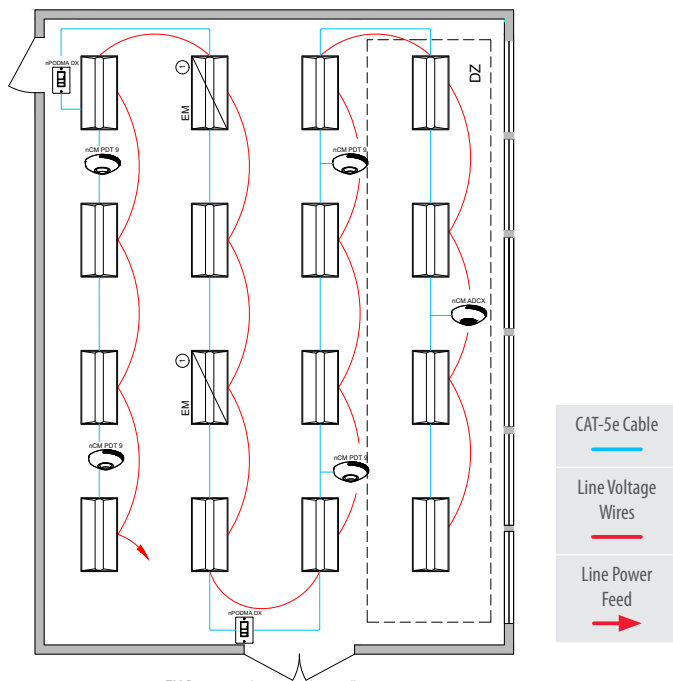

- ① Some emergency luminaires with networked embedded controls from nLight require a normal sense line connection. Wiring shown assumes battery backup emergency option. See fixture spec sheets for details.

## Wireless

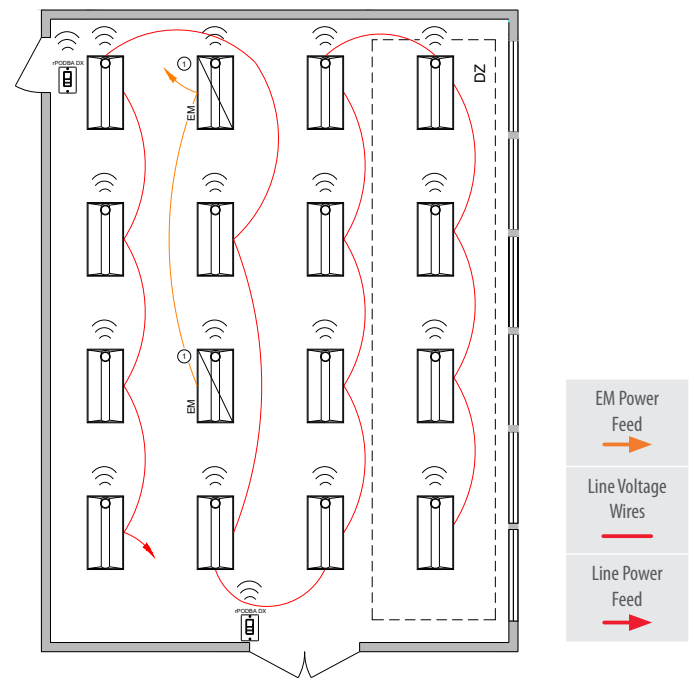

- ① Fixture(s) assumed to include power interruption detection emergency option. For battery backup option, no dedicated EM circuit necessary.

## Bill of Materials

Symbol	Qty	Product #	Description
	14	See Note	Troffer with Wired Networked Embedded Controls from nLight
	2	See Note	Troffer with Wired Networked Embedded Controls from nLight with Battery Option (typical)
	2	nPODMA DX	On/Off, Raise/Lower WallPod
	4	nCM PDT 9 RJB	Occupancy Sensor
	1	nCM ADCX RJB	Daylight Sensor

### OPERATIONAL DETAILS:

#### Light Fixtures:

- All fixtures are dimmable
- All fixtures are controlled together or independently
- Maximum level can be task tuned to any percentage via programming

#### Occupancy Control:

- Fixtures must be turned on manually (or optionally can be configured to come on automatically to 50%)
- Fixtures turn off automatically when room becomes vacant
- General lighting must be controlled in zones not greater than 600 sq. ft.

#### Daylight Control:

- Smooth continuous dimming
- Custom grouping of fixtures into separate daylight zones (max. number zones = number of fixtures)
- Not required for offices without windows or that have loads <150W in sidelit zones

#### Manual Control:

- On/off & raise/lower control of fixtures

**Note: Contact your local lighting agent for more information on luminaires with networked embedded controls from nLight. nLight wired or wireless networked control devices address the requirements of Luminaire Level Lighting Controls (LLLC), as specified in the IECC 2018 CODE.**

## Bill of Materials

Symbol	Qty	Product #	Description
	14	See Note	Troffer with Wireless Networked Embedded Controls from nLight with Sensor Option
	2	See Note	Troffer with Wireless Networked Embedded Controls from nLight with Sensor and Emergency Option
	2	rPODBA DX G2	Battery Powered, On/Off, Raise/Lower WallPod

### ADDITIONAL OPTIONS:

- Room can be connected to nLight backbone to enable network control or time schedules (C405.2.2.1 - Time-Switch Controls), and also qualify for Enhanced Digital Lighting Controls (C406.4)
- HVAC control available through system-wide BACnet® interface option on the ECLYPSE controller
- Luminaires with wireless networked embedded controls from nLight with occupancy/daylighting sensor options available, please see the fixture specification sheet
- nLight wired or wireless networked control devices address the monitoring and configuration requirements of Luminaire Level Lighting Controls (LLLC) (C405.2.1, C405.2.4, C405.2.5)
- Occupant sensor controls in open plan office spaces less than 300 sq. ft. in area shall comply with Section C405.2.1.1

**Wired**

**Wireless**

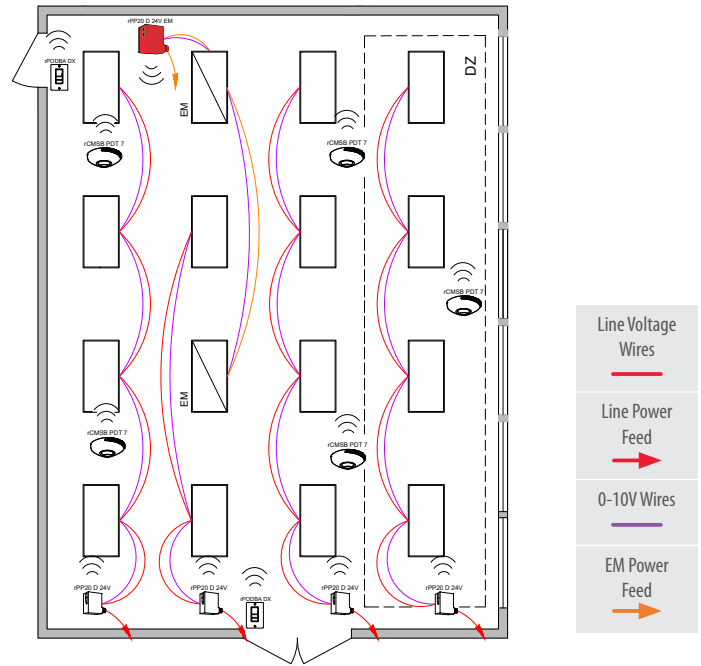
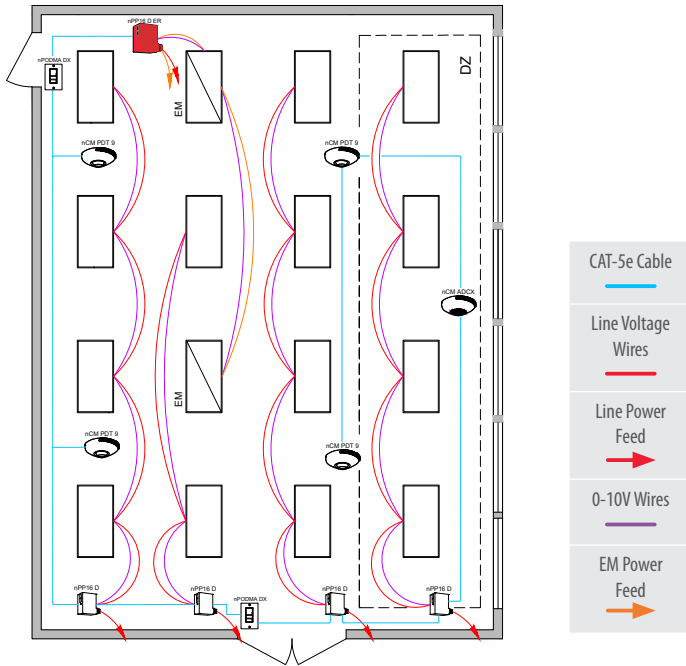

**Bill of Materials**

Symbol	Qty	Product #	Description
	4	nPP16 D EFP	Relay Pack with 0-10V Dimming Output
	1	nPP16 D ER EFP	Emergency Relay Pack with 0-10V Dimming Output
	2	nPODMA DX	On/Off, Raise/Lower WallPod
	4	nCM PDT 9 RJB	Occupancy Sensor
	1	nCM ADCX RJB	Daylight Sensor

**Bill of Materials**

Symbol	Qty	Product #	Description
	4	rPP20 D 24V EFP G2	Relay Pack with 0-10V Dimming Output
	1	rPP20 D 24V EM EFP G2	Emergency Relay Pack with 0-10V Dimming Output
	2	rPODBA DX G2	Battery Powered, On/Off, Raise/Lower WallPod
	5	rCMSB PDT 7 G2	Battery Powered Occupancy Sensor

**OPERATIONAL DETAILS:**

**Light Fixtures:**

- All fixtures are dimmable
- Each row controlled independently
- Maximum level can be task tuned to any percentage via programming

**Occupancy Control:**

- Fixtures must be turned on manually (or optionally can be configured to come on automatically to 50%)
- Fixtures turn off automatically when room becomes vacant
- General lighting must be controlled in zones not greater than 600 sq. ft.

**Daylight Control:**

- Smooth continuous dimming
- Daylight zones defined by rows
- Not required for offices without windows or that have loads <150W in sidelit zones

**Manual Control:**

- On/off & raise/lower control of fixtures

**ADDITIONAL OPTIONS:**

- Room can be connected to nLight backbone to enable network control or time schedules (C405.2.2.1 - Time-Switch Controls), and also qualify for Enhanced Digital Lighting Controls (C406.4)
- HVAC control available through system-wide BACnet® interface option on the ECLYPSE controller
- Occupant sensor controls in open plan office spaces less than 300 sq. ft. in area shall comply with Section C405.2.1.1

# CONFERENCE ROOM with Luminaires with Networked Embedded Controls from nLight

## Wired

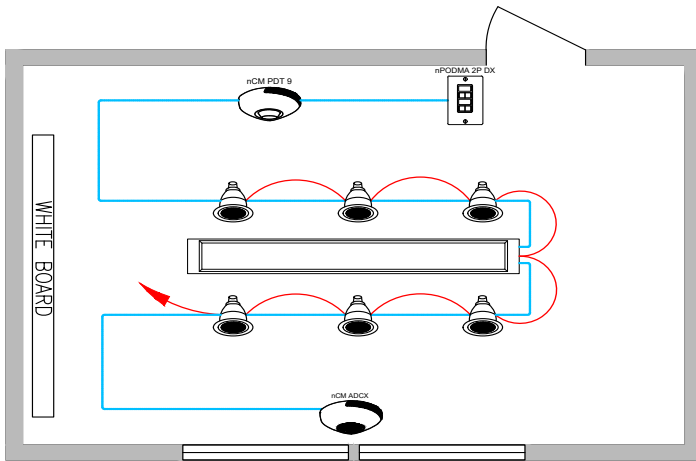

CAT-5e Cable

Line Voltage Wires

Line Power Feed

## Wireless

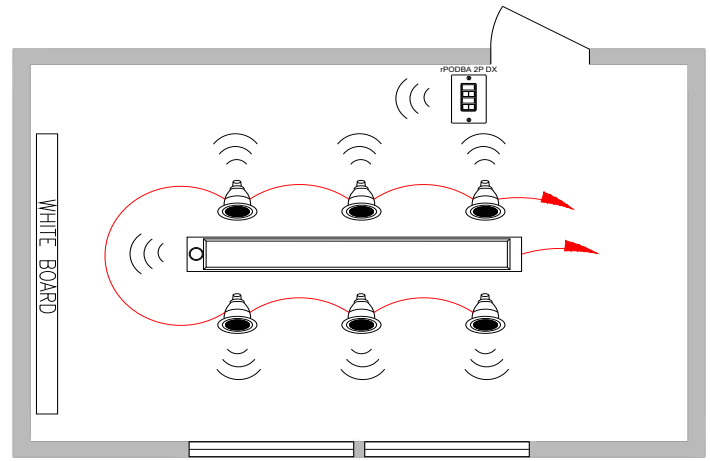

Line Voltage Wires

Line Power Feed

## Bill of Materials

Symbol	Qty	Product #	Description
	1	See Note	Luminaire with Wired Networked Embedded Controls From nLight
	6	See Note	Downlight with Wired Networked Embedded Controls From nLight
	1	nPODMA 2P DX	2-Pole, On/Off, Raise/Lower WallPod
	1	nCM PDT 9 RJB	Occupancy Sensor
	1	nCM ADCX RJB	Daylight Sensor

## Bill of Materials

Symbol	Qty	Product #	Description
	1	See Note	Luminaire with Wireless Networked Embedded Controls From nLight with Sensor Option
	6	See Note	Downlight with Wireless Networked Embedded Controls From nLight
	1	rPODBA 2P DX G2	Battery Powered, 2-Pole, On/Off, Raise/Lower WallPod

### OPERATIONAL DETAILS:

#### Light Fixtures:

- All fixtures are dimmable
- Maximum level can be task tuned to any percentage via programming
- A/V zone can be programmed to control two fixtures in front of the whiteboard

#### Occupancy Control:

- Fixtures must be turned on manually (or optionally can be configured to come on automatically to 50%)
- Fixtures turn off automatically when room becomes vacant

#### Daylight Control:

- Smooth continuous dimming
- Custom grouping of fixtures into separate daylight zones (max number zones = number of fixtures)
- Not required for areas without windows or that have loads <150w in sidelit zones

#### Manual Control:

- On/off & raise lower control of two zones of fixtures

### ADDITIONAL OPTIONS:

- Room can be connected to nLight backbone to enable network control or time schedules (C405.2.2.1 - Time-Switch Controls), and also qualify for Enhanced Digital Lighting Controls (C406.4)
- HVAC control available through system-wide BACnet® interface option on the ECLYPSE controller
- Luminaires with wireless networked embedded controls from nLight with occupancy/daylighting sensor options available, please see the fixture specification sheet
- nLight wired or wireless networked control devices address the monitoring and configuration requirements of Luminaire Level Lighting Controls (LLC) (C405.2.1, C405.2.4, C405.2.5)
- For emergency lighting control use a power pack with ER/EM option or luminaire with networked embedded controls from nLight with emergency option

**Note:** Contact your local lighting agent for more information on luminaires with networked embedded controls from nLight. nLight wired or wireless networked control devices address the requirements of Luminaire Level Lighting Controls (LLC), as specified in the IECC 2018 CODE.

**Wired**

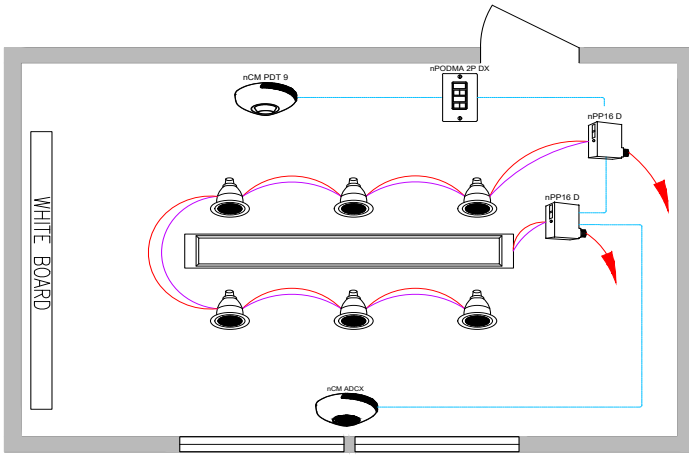

**Wireless**

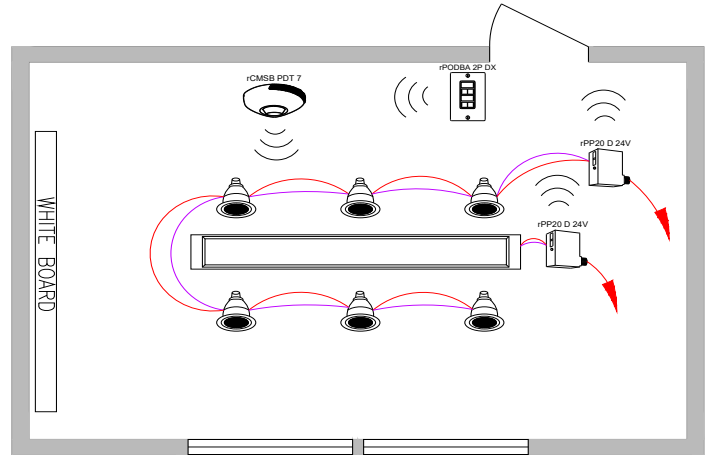

**Bill of Materials**

Symbol	Qty	Product #	Description
	2	nPP16 D EFP	Relay Pack with 0-10V Dimming Output
	1	nPODMA 2P DX	2-Pole, On/Off, Raise/Lower WallPod
	1	nCM PDT 9 RJB	Occupancy Sensor
	1	nCM ADCX RJB	Daylight Sensor

**Bill of Materials**

Symbol	Qty	Product #	Description
	2	rPP20 D 24V EFP G2	Relay Pack with 0-10V Dimming Output
	1	rPODBA 2P DX G2	Battery Powered, 2-Pole, On/Off, Raise/Lower WallPod
	1	rCMSB PDT 7 G2	Battery Powered Occupancy and Daylight Sensor

**OPERATIONAL DETAILS:**

**Light Fixtures:**

- All fixtures are dimmable
- Maximum level can be task tuned to any percentage via programming

**Occupancy Control:**

- Fixtures must be turned on manually (or optionally can be configured to come on automatically to 50%)
- Fixtures turn off automatically when room becomes vacant

**Daylight Control:**

- Smooth continuous dimming
- Daylight zones defined by rows
- Not required for areas without windows or that have loads <150W in sidelit zones

**Manual Control:**

- On/off & raise lower control of two zones of fixtures

**ADDITIONAL OPTIONS:**

- Room can be connected to nLight backbone to enable network control or time schedules (C405.2.2.1 - Time-Switch Controls), and also qualify for Enhanced Digital Lighting Controls (C406.4)
- HVAC control available through system-wide BACnet® interface option on the ECLYPSE controller
- For emergency lighting control use a power pack with ER/EM option or luminaire with networked embedded controls from nLight with emergency option

## Wired

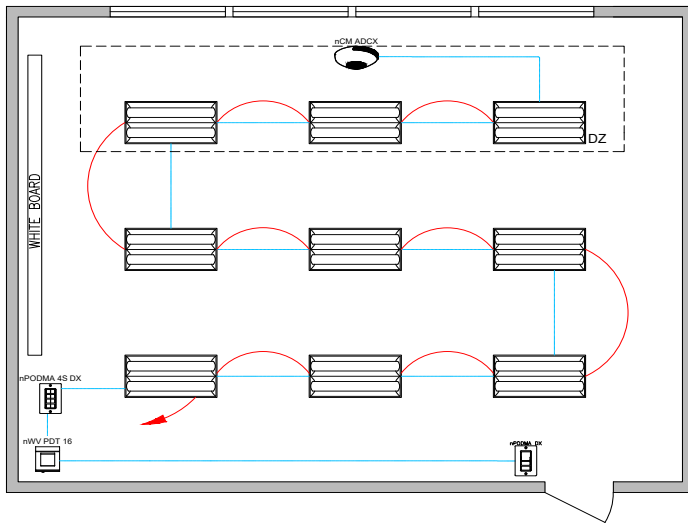

## Wireless

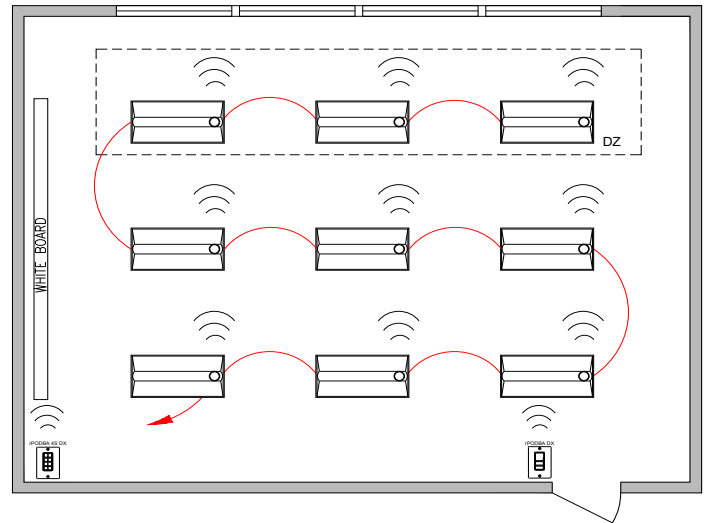

### Bill of Materials

Symbol	Qty	Product #	Description
	9	See Note	Troffer with Wired Networked Embedded Controls from nLight
	1	nPODMA DX	On/Off, Raise/Lower WallPod
	1	nWV PDT 16	Dual Technology Wide View Occupancy Sensor
	1	nPODMA 4S DX	Teacher Station — 4 Scene Control with Master On/Off & Raise/Lower
	1	nCM ADCX RJB	Daylight Sensor

### Bill of Materials

Symbol	Qty	Product #	Description
	9	See Note	Troffer with Wireless Networked Embedded Controls from nLight with Sensor Option
	1	rPODBA DX G2	Battery Powered, On/Off, Raise/Lower WallPod
	1	rPODBA 4S DX G2	Teacher Station — Battery Powered 4 Scene Control with Master On/Off & Raise/Lower

#### OPERATIONAL DETAILS:

##### Light Fixtures:

- All fixtures are dimmable
- All fixtures are controlled together or independently
- Maximum level can be task tuned to any percentage via programming

##### Occupancy Control:

- Fixtures must be turned on manually (or optionally can be configured to some on automatically to 50%)
- Fixtures automatically turn off when room becomes vacant

##### Daylight Control:

- Smooth continuous dimming
- Custom grouping of fixtures into separate daylight zones (max number zones = number of fixtures)
- Not required for areas without windows or that have loads <150W in sidelit zones

##### Manual Control:

- On/off & raise/lower control of entire room
- Teacher station with 4 preset scenes

#### ADDITIONAL OPTIONS:

- Room can be connected to nLight backbone to enable network control or time schedules (C405.2.2.1 - Time-Switch Controls), and also qualify for Enhanced Digital Lighting Controls (C406.4)
- HVAC control available through system-wide BACnet® interface option on the ECLYPSE controller
- Luminaires with wireless networked embedded controls from nLight with occupancy/daylighting sensor options available, please see the fixture specification sheet
- nLight wired or wireless networked control devices address the monitoring and configuration requirements of Luminaire Level Lighting Controls (LLC) (C405.2.1, C405.2.4, C405.2.5)
- For emergency lighting control use a power pack with ER/EM option or luminaire with networked embedded controls from nLight with emergency option.

**Note: Contact your local lighting agent for more information on luminaires with networked embedded controls from nLight. nLight wired or wireless networked control devices address the requirements of Luminaire Level Lighting Controls (LLC), as specified in the IECC 2018 CODE.**

**Wired**

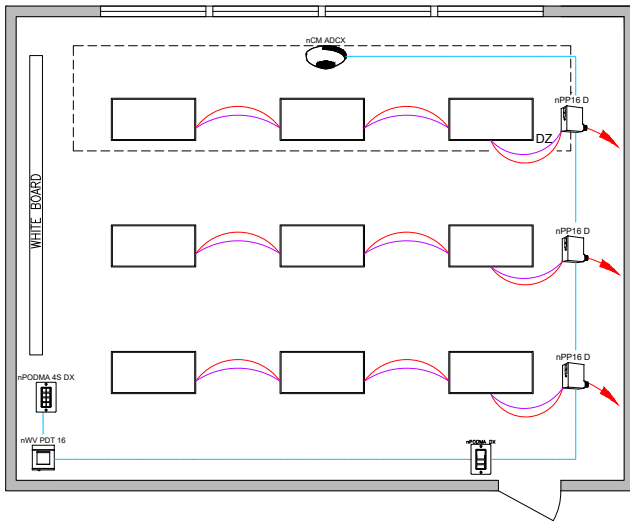

**Wireless**

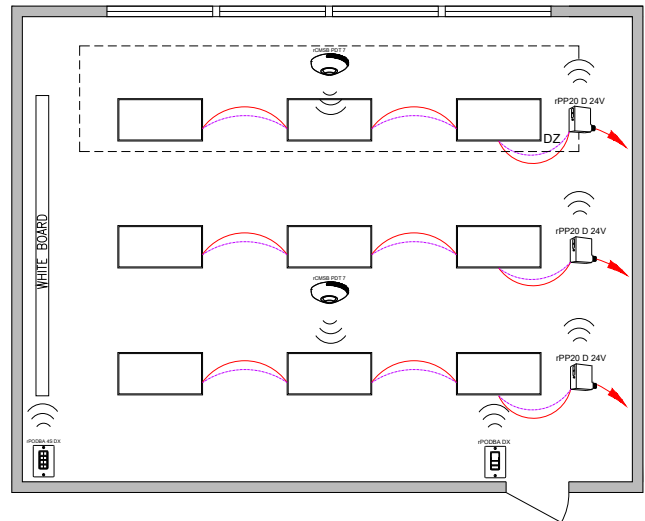

**Bill of Materials**

Symbol	Qty	Product #	Description
	3	nPP16 D EFP	Relay Module with 0-10V Dimming Output
	1	nPODMA DX	On/Off, Raise/Lower WallPod
	1	nWV PDT 16	Dual Technology Wide View Occupancy Sensor
	1	nPODMA 4S DX	Teacher Station — 4 Scene Control with Master On/Off & Raise/Lower
	1	nCM ADCX RJB	Daylight Sensor

**Bill of Materials**

Symbol	Qty	Product #	Description
	3	rPP20 D 24V EFP G2	Relay Pack with 0-10V Dimming Output
	1	rPODBA DX G2	Battery Powered, On/Off, Raise/Lower WallPod
	2	rCMSB PDT 7 G2	Battery Powered Occupancy and Daylight Sensor
	1	rPODBA 4S DX G2	Teacher Station — Battery Powered 4 Scene Control with Master On/Off & Raise/Lower

**OPERATIONAL DETAILS:**

**Light Fixtures:**

- All fixtures are dimmable
- Each row can be controlled independently
- Maximum level can be task tuned to any percentage via programming

**Occupancy Control:**

- Fixtures must be turned on manually (or optionally can be configured to come on automatically to 50%)
- Fixtures automatically turn off when room becomes vacant

**Daylight Control:**

- Smooth continuous dimming
- Daylight zones defined by rows
- Not required for areas without windows or that have loads <150W in sidelit zones

**Manual Control:**

- Master on/off & raise/lower control of entire room
- Teacher station with 4 preset scenes

**ADDITIONAL OPTIONS:**

- Room can be connected to nLight backbone to enable network control or time schedules (C405.2.2.1 - Time-Switch Controls), and also qualify for Enhanced Digital Lighting Controls (C406.4)
- HVAC control available through system-wide BACnet® interface option on the ECLYPSE controller
- For emergency lighting control use a power pack with ER/EM option or luminaire with networked embedded controls from nLight with emergency option.

## Wired

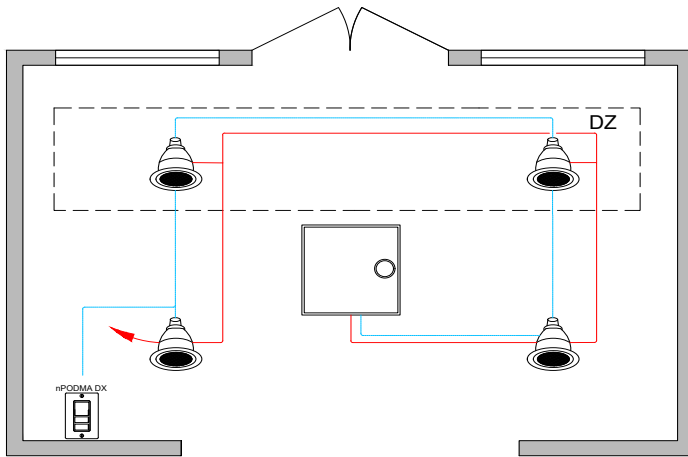

CAT-5e Cable

Line Voltage Wires

Line Power Feed

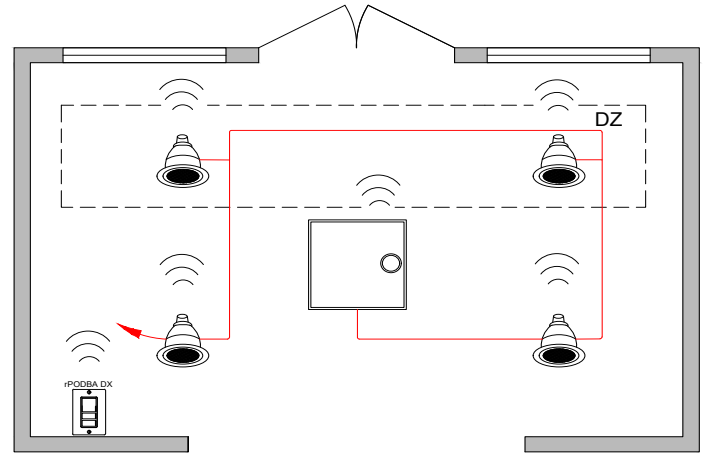

## Wireless





Line Voltage Wires

Line Power Feed

## Bill of Materials

Symbol	Qty	Product #	Description
	4	See Notes	Downlight with Wired Networked Embedded Controls from nLight
	1	See Notes	Troffer with Wired Networked Embedded Controls from nLight
	1	nPODMA DX	On/Off, Raise/Lower WallPod

## Bill of Materials

Symbol	Qty	Product #	Description
	4	See Notes	Downlight with Wireless Networked Embedded Controls from nLight
	1	See Notes	Luminaire with Wireless Networked Embedded Controls from nLight and Sensor Option
	1	rPODBA DX G2	Battery Powered, On/Off, Raise/Lower WallPod

## / OPERATIONAL DETAILS:

## Light Fixtures:

- All fixtures are dimmable
- Maximum level can be task tuned to any percentage via programming

## Occupancy Control:

- Fixtures automatically go to full bright when occupied
- Fixtures automatically turn off when room becomes vacant

## Daylight Control:

- Smooth continuous dimming
- Custom grouping of fixtures into separate daylight zones (max number zones = number of fixtures)
- Not required for areas without windows or that have loads <150W in sidelit zones

## Manual Control:

- On/off & raise/lower control of fixtures

## / ADDITIONAL OPTIONS:

- Room can be connected to nLight backbone to enable network control or time schedules (C405.2.2.1 - Time-Switch Controls), and also qualify for Enhanced Digital Lighting Controls (C406.4)
- HVAC control available through system-wide BACnet® interface option on the ECLYPSE controller
- Luminaires with wireless networked embedded controls from nLight with occupancy/daylighting sensor options available, please see the fixture specification sheet
- nLight wired or wireless networked control devices address the monitoring and configuration requirements of Luminaire Level Lighting Controls (LLC) (C405.2.1, C405.2.4, C405.2.5)
- For emergency lighting control use a power pack with ER/EM option or luminaire with networked embedded controls from nLight with emergency option

**Note:** Contact your local lighting agent for more information on luminaires with networked embedded controls from nLight. nLight wired or wireless networked control devices address the requirements of Luminaire Level Lighting Controls (LLC), as specified in the IECC 2018 CODE.



**Wired**

**Wireless**

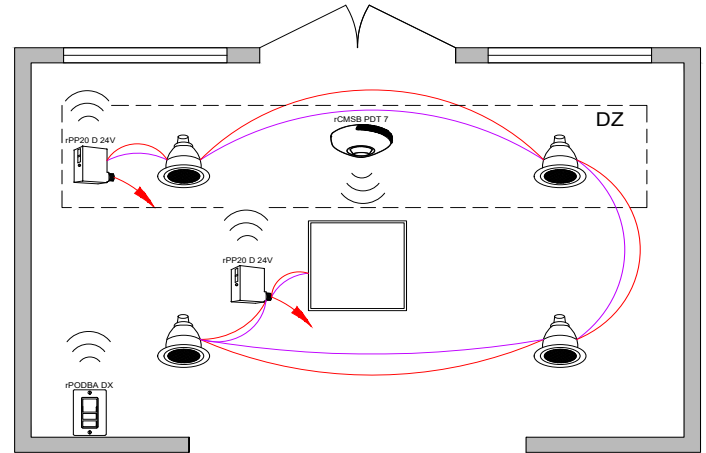
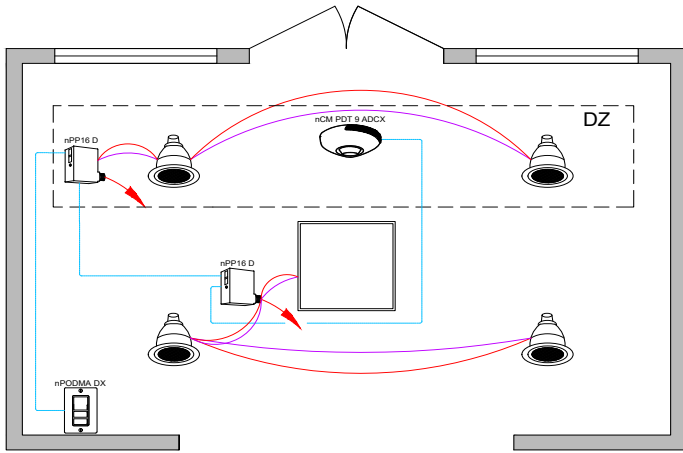

**Bill of Materials**

**Bill of Materials**

Symbol	Qty	Product #	Description
	2	nPP16 D EFP	Relay Pack with 0-10V Dimming Output
	1	nPODMA DX	On/Off, Raise/Lower WallPod
	1	nCM PDT 9 ADCX	Occupancy and Daylight Sensor

Symbol	Qty	Product #	Description
	2	rPP20 D 24V EFP G2	Relay Pack with 0-10V Dimming Output
	1	rPODBA DX G2	Battery Powered, On/Off, Raise/Lower WallPod
	1	rCMSB PDT 7 G2	Battery Powered Occupancy and Daylight Sensor

**/ OPERATIONAL DETAILS:**

**/ ADDITIONAL OPTIONS:**

**Light Fixtures:**

- All fixtures are dimmable
- Maximum level can be task tuned to any percentage via programming

**Occupancy Control:**

- Fixtures automatically go to full bright when occupied
- Fixtures automatically turn off when room becomes vacant

**Daylight Control:**

- Smooth continuous dimming
- Daylight zones defined by relay module wiring
- Not required for areas without windows or that have loads <150W in sidelit zones

**Manual Control:**

- On/off & raise/lower control of fixtures



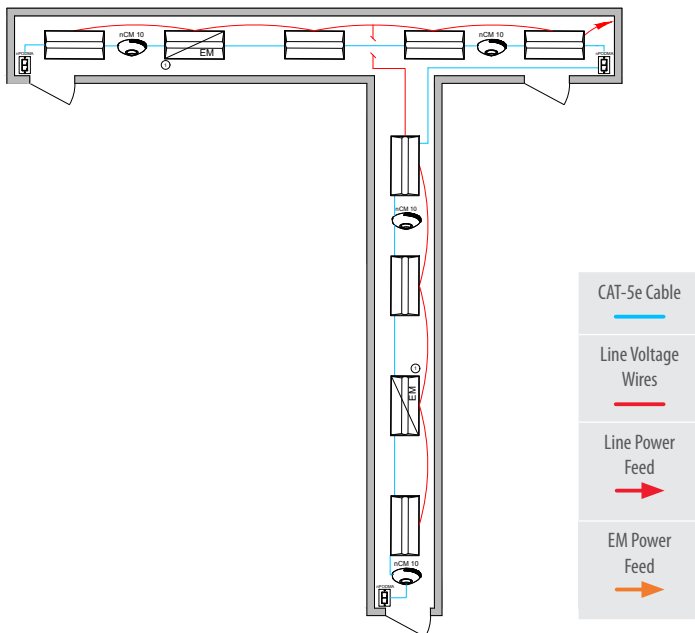

- Room can be connected to nLight backbone to enable network control or time schedules (C405.2.2.1 - Time-Switch Controls), and also qualify for Enhanced Digital Lighting Controls (C406.4)
- HVAC control available through system-wide BACnet® interface option on the ECLYPSE controller
- For emergency lighting control use a power pack with ER/EM option or luminaire with networked embedded controls from nLight with emergency option

## Wired



- ① Some emergency luminaires with networked embedded controls from nLight require a normal sense line connection. Wiring shown assumes battery backup emergency option. See fixture spec sheets for details.

## Bill of Materials

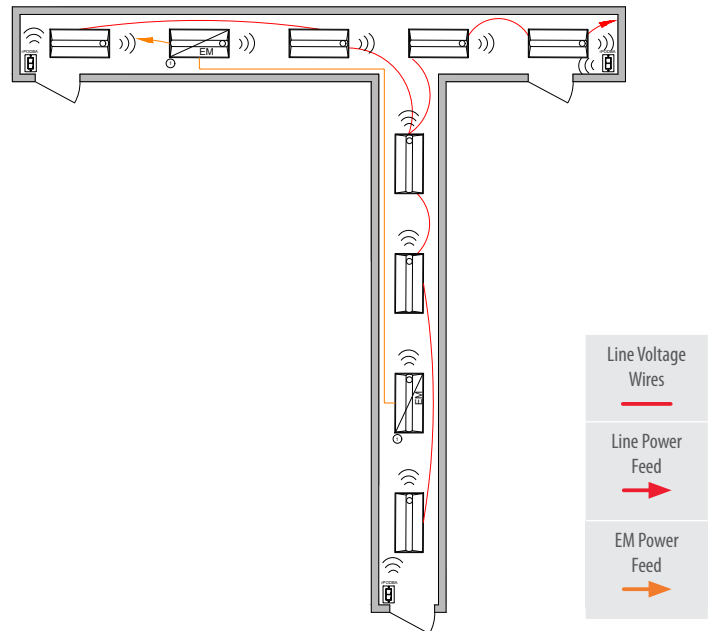

Symbol	Qty	Product #	Description
	7	See Note	Troffer with Wired Networked Embedded Controls from nLight
	2	See Note	Troffer with Wired Networked Embedded Controls from nLight with Battery Option
	3	nPODMA	On/Off WallPod
	4	nCM 10 RJB	Occupancy Sensor

## Wireless



- ① Fixture(s) assumed to include power interruption detection emergency option. For battery backup option, no dedicated EM circuit necessary.

## Bill of Materials

Symbol	Qty	Product #	Description
	7	See Note	Troffer with Wireless Networked Embedded Controls with Sensor Option
	2	See Note	Troffer with Wireless Networked Embedded Controls with Sensor and Emergency Option
	3	rPODBA G2	Battery Powered, On/Off, Raise/Lower WallPod

### / OPERATIONAL DETAILS:

#### Light Fixtures:

- All fixtures are dimmable
- All fixtures are controlled together or independently
- Maximum level can be task tuned to any percentage via programming

#### Occupancy Control:

- Fixtures automatically go to full bright when occupied
- Fixtures automatically turn off or optionally can be configured to drop to low dim setting when space becomes vacant

#### Manual Control:

- On/off control of fixtures

**Note:** Contact your local lighting agent for more information on luminaires with networked embedded controls from nLight. nLight wired or wireless networked control devices address the requirements of Luminaire Level Lighting Controls (LLLC), as specified in the IECC 2018 CODE.

### / ADDITIONAL OPTIONS:

- Room can be connected to nLight backbone to enable network control or time schedules (C405.2.2.1 - Time-Switch Controls), and also qualify for Enhanced Digital Lighting Controls (C406.4)
- HVAC control available through system-wide BACnet® interface option on the ECLYPSE controller
- Luminaires with wireless networked embedded controls from nLight with occupancy/daylighting sensor options available, please see the fixture specification sheet
- nLight wired or wireless networked control devices address the monitoring and configuration requirements of Luminaire Level Lighting Controls (LLLC) (C405.2.1, C405.2.4, C405.2.5)



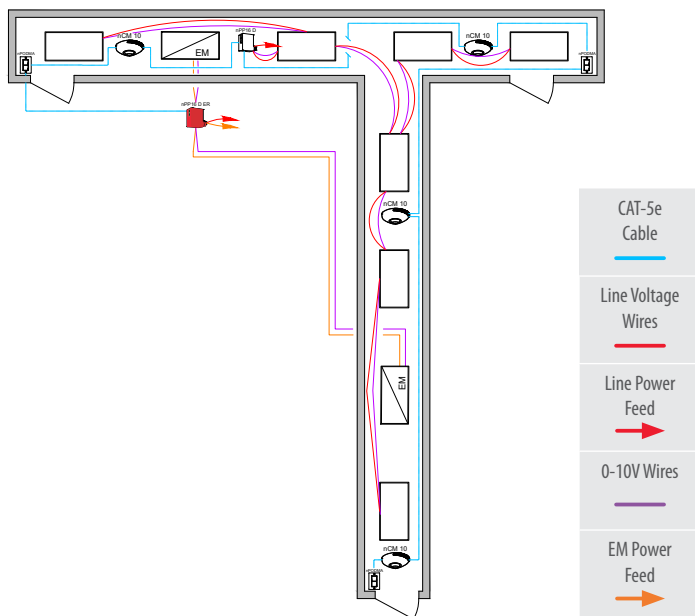

## Wired

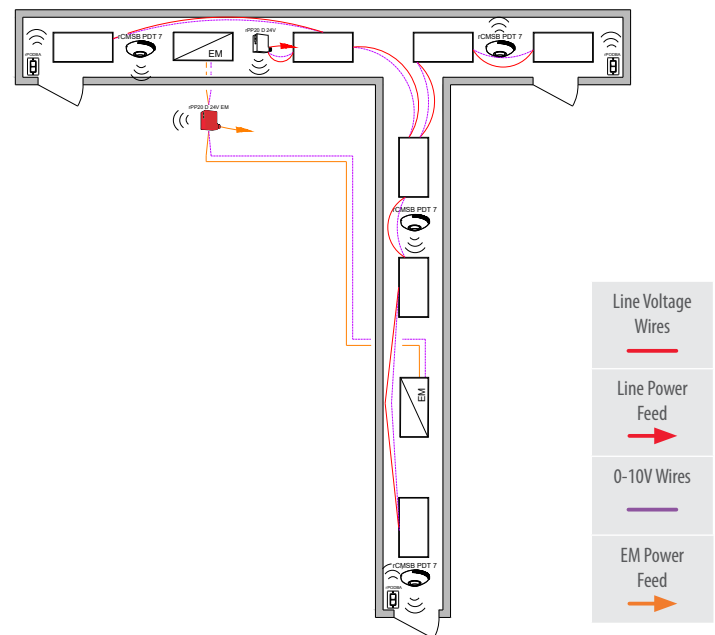





## Wireless



## Bill of Materials

Symbol	Qty	Product #	Description
	1	nPP16 D EFP	Relay Pack with 0-10V Dimming Output
	1	nPP16 D ER EFP	Emergency Relay Pack with 0-10V Dimming Output
	4	nCM 10 RJB	Occupancy Sensor
	3	nPODMA	On/Off WallPod

## Bill of Materials

Symbol	Qty	Product #	Description
	1	rPP20 D 24V EFP G2	Relay Pack with 0-10V Dimming Output
	1	rPP20 D 24V EM EFP G2	Emergency Relay Pack with 0-10V Dimming Output
	4	rCMSB PDT 7 G2	Battery Powered Occupancy Sensor
	3	rPODBA G2	Battery Powered, On/Off, Raise/Lower WallPod

## / OPERATIONAL DETAILS:

**Light Fixtures:**

- All fixtures are dimmable
- Maximum level can be task tuned to any percentage via programming

**Occupancy Control:**

- Fixtures automatically go to full bright when occupied
- Fixtures automatically turn off or optionally can be configured to drop to low dim setting when space becomes vacant

**Manual Control:**

- On/off control of fixtures

## / ADDITIONAL OPTIONS:

- Room can be connected to nLight backbone to enable network control or time schedules (C405.2.2.1 - Time-Switch Controls), and also qualify for Enhanced Digital Lighting Controls (C406.4)
- HVAC control available through system-wide BACnet® interface option on the ECLYPSE controller
- For emergency lighting control use a power pack with ER/EM option or luminaire with networked embedded controls from nLight with emergency option

## Wired

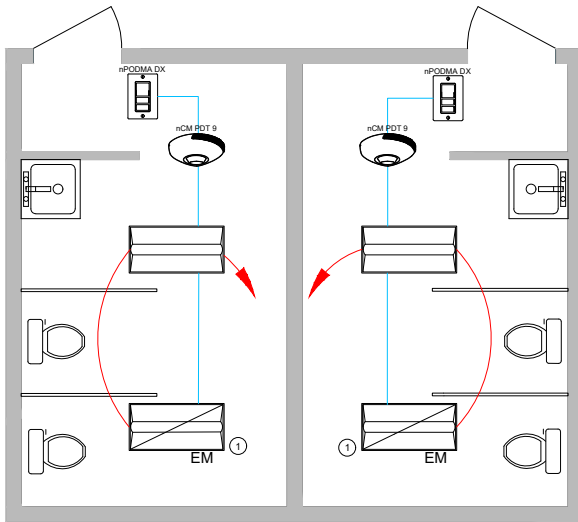

① Some emergency luminaires with networked embedded controls from nLight require a normal sense line connection. Wiring shown assumes battery backup emergency option. See fixture spec sheets for details.



## Wireless

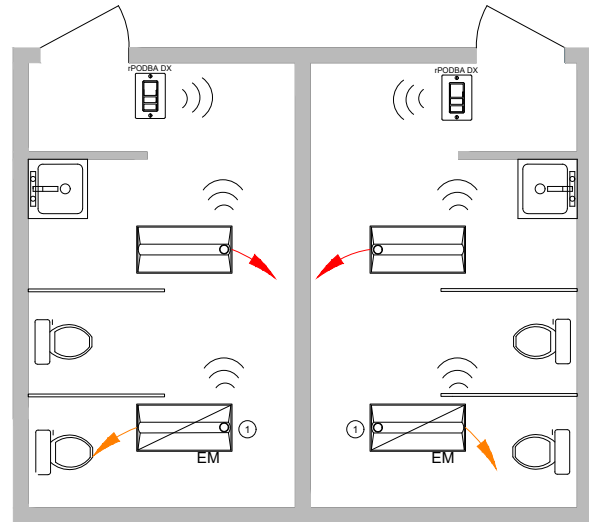

① Fixture(s) assumed to include power interruption detection emergency option. For battery backup option, no dedicated EM circuit necessary.



### Bill of Materials

Symbol	Qty	Product #	Description
	2	See Note	Troffer with Wireless Networked Embedded Controls from nLight
	2	See Note	Troffer with Wired Networked Embedded Controls from nLight with Battery Option
	2	nPODMA DX	On/Off, Raise/Lower WallPod

### Bill of Materials

Symbol	Qty	Product #	Description
	2	See Note	Troffer with Wireless Networked Embedded Controls from nLight with Sensor Option
	2	See Note	Troffer with Wireless Networked Embedded Controls from nLight with Sensor and Emergency Option
	2	rPODBA DX G2	Battery Powered, On/Off, Raise/Lower WallPod

### OPERATIONAL DETAILS:

#### Light Fixtures:

- All fixtures are dimmable
- All fixtures are controlled together or independently (per room)
- Maximum level can be task tuned to any percentage via programming

#### Occupancy Control:

- Fixtures automatically go to full bright when occupied (or optionally can be configured to come on automatically to 50%)
- Fixtures automatically turn off or optionally can be configured to drop to low dim setting when space becomes vacant

#### Manual Control:

- On/off & raise/lower control of fixtures
- If switch poses safety concerns, optionally can be programmed for "on only"

### ADDITIONAL OPTIONS:

- Room can be connected to nLight backbone to enable network control or time schedules (C405.2.2.1 - Time-Switch Controls), and also qualify for Enhanced Digital Lighting Controls (C406.4)
- HVAC control available through system-wide BACnet® interface option on the ECLYPSE controller
- Luminaires with wireless networked embedded controls from nLight with occupancy/daylighting sensor options available, please see the fixture specification sheet
- nLight wired or wireless networked control devices address the monitoring and configuration requirements of Luminaire Level Lighting Controls (LLC) (C405.2.1, C405.2.4, C405.2.5)

**Note:** Contact your local lighting agent for more information on luminaires with networked embedded controls from nLight. nLight wired or wireless networked control devices address the requirements of Luminaire Level Lighting Controls (LLC), as specified in the IECC 2018 CODE.

**Wired**

**Wireless**

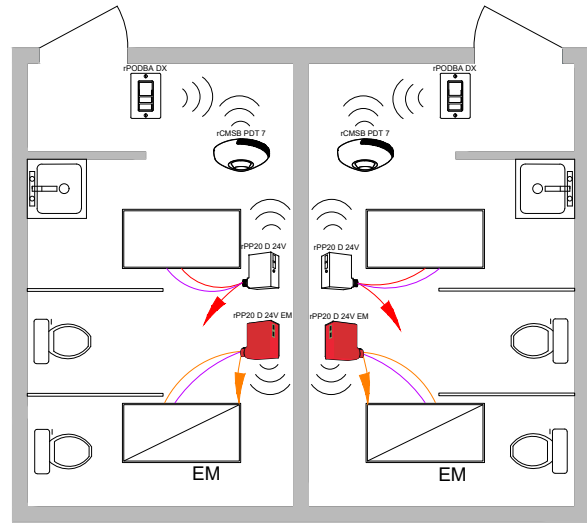
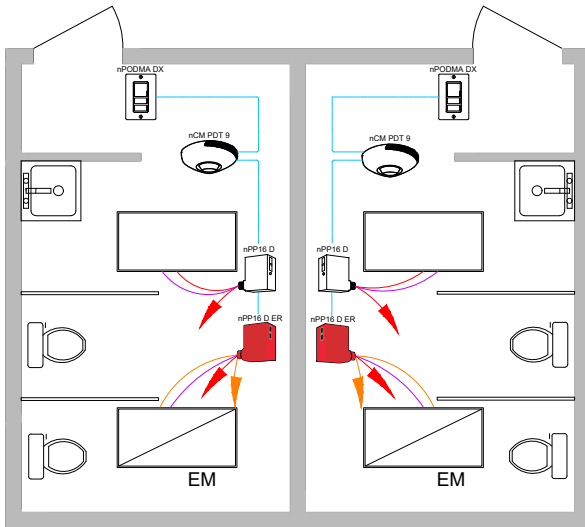

**Bill of Materials**

Symbol	Qty	Product #	Description
	2	nPP16 D EFP	Relay Pack with 0-10V Dimming Output
	2	nPP16 D ER EFP	Emergency Module with 0-10V Dimming Output
	2	nPODMA DX	On/Off & Raise/Lower WallPod
	2	nCM PDT 9 RJB	Occupancy Sensor

**Bill of Materials**

Symbol	Qty	Product #	Description
	2	rPP20 D 24V EFP G2	Relay Pack with 0-10V Dimming Output
	2	rPP20 D 24V EM EFP G2	Emergency Relay Pack with 0-10V Dimming Output
	2	rPODBA DX G2	Battery Powered, On/Off & Raise/Lower WallPod
	2	rCMSB PDT 7 G2	Battery Powered Occupancy Sensor

**OPERATIONAL DETAILS:**

**Light Fixtures:**

- All fixtures are dimmable
- All fixtures are controlled together or independently (per room)
- Maximum level can be task tuned to any percentage via programming

**Occupancy Control:**

- Fixtures automatically go to full bright when occupied (or optionally can be configured to come on automatically to 50%)
- Fixtures automatically turn off or optionally can be configured to drop to low dim setting when space becomes vacant

**Manual Control:**

- On/off & raise/lower control of fixtures
- If switch poses safety concerns, optionally can be programmed for "on only"

**ADDITIONAL OPTIONS:**

- Room can be connected to nLight backbone to enable network control or time schedules (C405.2.2.1 - Time-Switch Controls), and also qualify for Enhanced Digital Lighting Controls (C406.4)
- HVAC control available through system-wide BACnet® interface option on the ECLYPSE controller
- Luminaires with wireless networked embedded controls from nLight with occupancy/daylighting sensor options available, please see the fixture specification sheet
- For emergency lighting control use a power pack with ER/EM option or luminaire with networked embedded controls from nLight with emergency option

**Note: Contact your local lighting agent for more information on luminaires with networked embedded controls from nLight. nLight wired or wireless networked control devices address the requirements of Luminaire Level Lighting Controls (LLC), as specified in the IECC 2018 CODE.**

**Wired**

**Wireless**

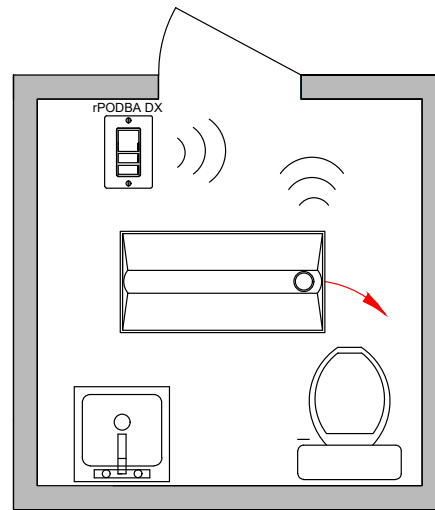
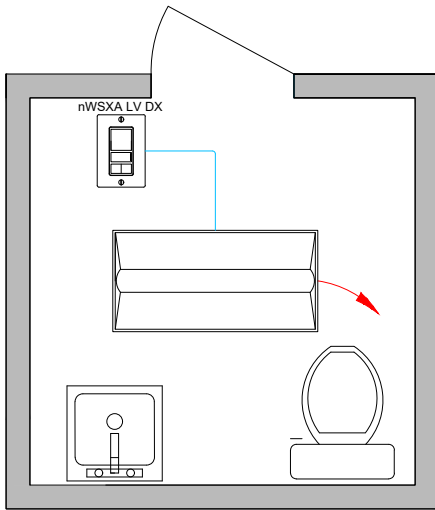

**Bill of Materials**

Symbol	Qty	Product #	Description
	1	See Note	Troffer with Wired Networked Embedded Controls from nLight
	1	nWSXA PDT LV DX	Occupancy Wall Switch, On/Off, Raise/Lower

**Bill of Materials**

Symbol	Qty	Product #	Description
	1	See Notes	Troffer with Wireless Networked Embedded Controls from nLight and Sensor Option
	1	rPODBA DX G2	Battery Powered, On/Off, Raise/ Lower WallPod

**OPERATIONAL DETAILS:**

**Light Fixtures:**

- All fixtures are dimmable
- Maximum level can be task tuned to any percentage via programming

**Occupancy Control:**

- Fixtures automatically go to full bright when occupied (or optionally can be configured to come on automatically to 50%)
- Fixtures automatically turn off or optionally can be configured to drop to low dim setting when space becomes vacant

**Manual Control:**

- On/off & raise/lower control of fixtures
- If switch poses safety concerns, optionally can be programmed for "on only"

**ADDITIONAL OPTIONS:**

- Room can be connected to nLight backbone to enable network control or time schedules (C405.2.2.1 - Time-Switch Controls), and also qualify for Enhanced Digital Lighting Controls (C406.4)
- HVAC control available through system-wide BACnet® interface option on the ECLYPSE controller
- Luminaires with wireless networked embedded controls from nLight with occupancy/daylighting sensor options available, please see the fixture specification sheet
- nLight wired or wireless networked control devices address the monitoring and configuration requirements of Luminaire Level Lighting Controls (LLC) (C405.2.1, C405.2.4, C405.2.5)
- For emergency lighting control use a power pack with ER/EM option or luminaire with networked embedded controls from nLight with emergency option.

**Note:** Contact your local lighting agent for more information on luminaires with networked embedded controls from nLight. nLight wired or wireless networked control devices address the requirements of Luminaire Level Lighting Controls (LLC), as specified in the IECC 2018 CODE.

## Luminaires with Networked Embedded Controls from nLight

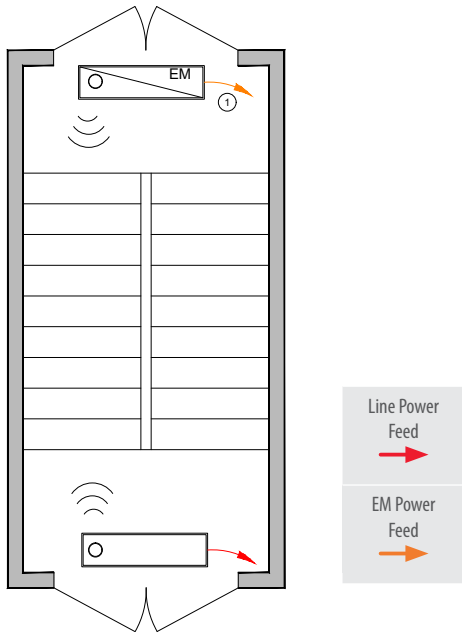

① Fixture(s) assumed to include power interruption detection emergency option. For battery backup option, no dedicated EM circuit necessary.

## Wireless with 0-10V Dimming Fixtures

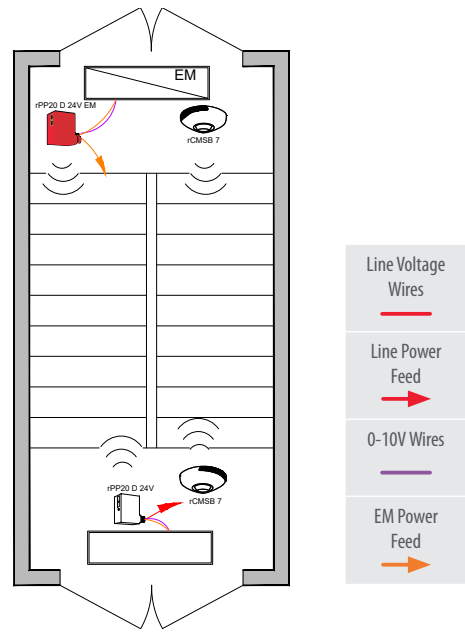

### Bill of Materials

Symbol	Qty	Product #	Description
	1	See Note	Luminaire with Wireless Networked Embedded Controls from nLight AIR with Sensor Option
	1	See Note	Luminaire with Wireless Networked Embedded Controls from nLight with Sensor and Emergency Option

### Bill of Materials

Symbol	Qty	Product #	Description
	1	rPP20 D 24V EFP G2	Relay Pack with 0-10V Dimming Output
	1	rPP20 D 24V EM EFP G2	Emergency Relay Pack with 0-10V Dimming Output
	2	rCMSB PDT 7 G2	Battery Powered Occupancy Sensor

### OPERATIONAL DETAILS:

#### Light Fixtures:

- All fixtures are dimmable
- Maximum level can be task tuned to any percentage via programming

#### Occupancy Control:

- Fixtures automatically go to full bright when occupied
- Fixtures automatically turn off or optionally can be configured to drop to low dim setting when space becomes vacant

#### Manual Control:

- Safety may preclude the use of a manual control in these areas

**Note:** Contact your local lighting agent for more information on luminaires with networked embedded controls from nLight. nLight wired or wireless networked control devices address the requirements of Luminaire Level Lighting Controls (LLLC), as specified in the IECC 2018 CODE.

### ADDITIONAL OPTIONS:

- Room can be connected to nLight backbone to enable network control or time schedules (C405.2.2.1 - Time-Switch Controls), and also qualify for Enhanced Digital Lighting Controls (C406.4)
- HVAC control available through system-wide BACnet® interface option on the ECLYPSE controller
- Luminaires with wireless networked embedded controls from nLight with occupancy/daylighting sensor options available, please see the fixture specification sheet
- nLight wired or wireless networked control devices address the monitoring and configuration requirements of Luminaire Level Lighting Controls (LLLC) (C405.2.1, C405.2.4, C405.2.5)
- For emergency lighting control use a power pack with ER/EM option or luminaire with networked embedded controls from nLight with emergency option

## Luminaires with Wireless Networked Embedded Controls from nLight

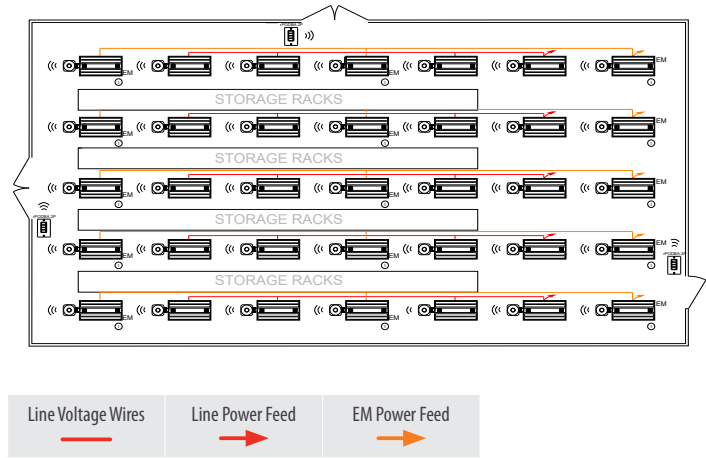

### Bill of Materials

Symbol	Qty	Product #	Description
	20	See Note	High Bay Luminaire with Wireless Networked Embedded Controls from nLight with Sensor Option
	15	See Note	High Bay Luminaire with Wireless Networked Embedded Controls from nLight with Sensor and Emergency Option
	3	rPODBA 2P G2	Battery Powered, 2-Pole, On/Off WallPod

### OPERATIONAL DETAILS:

#### Light Fixtures:

- All fixtures are dimmable
- Maximum level can be task tuned to any percentage via programming

#### Occupancy Control:

- Fixtures automatically go to full bright when occupied
- Fixtures automatically turn off or optionally can be configured to drop to low dim setting when space becomes vacant

#### Daylight Control:

- Daylight responsive controls lights to full off when adequate daylight present
- Not required for spaces without skylights or that have loads <150W in toplit zones

**Note:** Contact your local lighting agent for more information on luminaires with networked embedded controls from nLight. nLight wired or wireless networked control devices address the requirements of Luminaire Level Lighting Controls (LLC), as specified in the IECC 2018 CODE.

## Wireless with 0-10V Dimming Fixtures

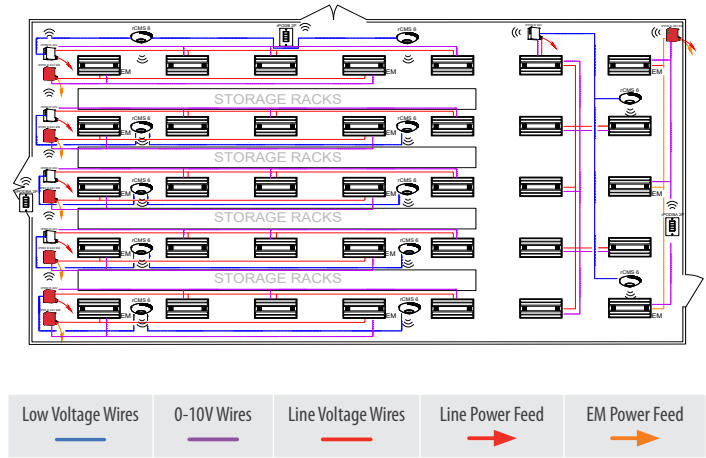

### Bill of Materials

Symbol	Qty	Product #	Description
	6	rPP20 D 24V EFP G2	Relay Pack with 0-10V Dimming Output
	6	rPP20 D 24V EM EFP G2	Emergency Relay Pack with 0-10V Dimming Output
	3	rPODBA 2P G2	Battery Powered, 2-Pole, On/Off WallPod
	12	rCMS 6 G2	Occupancy Sensor

### ADDITIONAL OPTIONS:

- Room can be connected to nLight backbone to enable network control or time schedules (C405.2.2.1 - Time-Switch Controls), and also qualify for Enhanced Digital Lighting Controls (C406.4)
- HVAC control available through system-wide BACnet® interface option on the ECLYPSE controller
- Luminaires with wireless networked embedded controls from nLight with occupancy/daylighting sensor options available, please see the fixture specification sheet
- nLight wired or wireless networked control devices address the monitoring and configuration requirements of Luminaire Level Lighting Controls (LLC) (C405.2.1, C405.2.4, C405.2.5)



**Luminaires with Wireless Networked Embedded Controls from nLight**

**Wireless with 0-10V Dimming Fixtures**

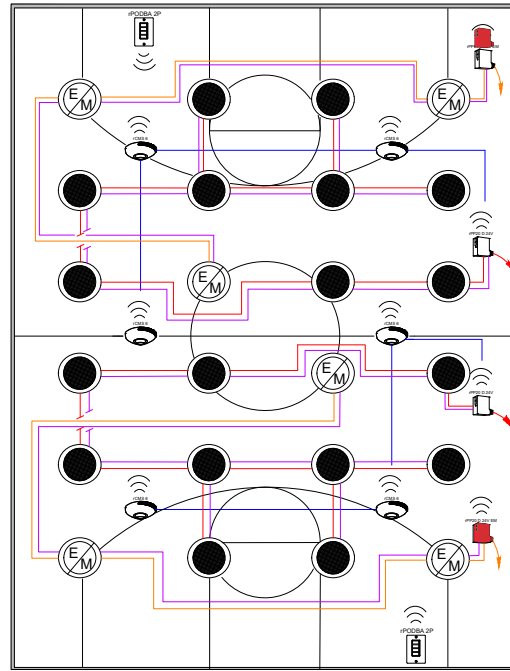
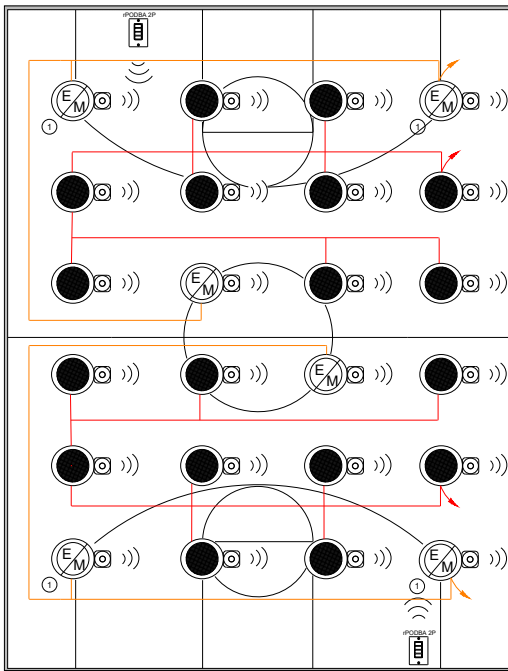

**Bill of Materials**

Symbol	Qty	Product #	Description
	18	See Notes	Luminaire with Wireless Networked Embedded Controls from nLight and Sensor Option
	6	See Notes	Luminaire with Wireless Networked Embedded Controls from nLight and Sensor and Emergency Option
	2	rPODBA 2P G2	Battery Powered, 2-Pole, On/Off WallPod

**Bill of Materials**

Symbol	Qty	Product #	Description
	2	rPP20 D 24V EFP G2	Relay Pack with 0-10V Dimming Output
	2	rPP20 D 24V EM	Emergency Relay Pack with 0-10V Dimming Output
	2	rPODBA 2P G2	Battery Powered, 2-Pole, On/Off WallPod
	6	rCMS 6 G2	High Bay Occupancy Sensor

**OPERATIONAL DETAILS:**

**Light Fixtures:**

- All fixtures are dimmable
- Maximum level can be task tuned to any percentage via programming

**Occupancy Control:**

- Fixtures automatically go to full bright when occupied
- Fixtures automatically turn off or optionally can be configured to drop to low dim setting when space becomes vacant

**Daylight Control:**

- Daylight responsive controls lights to full off when adequate daylight present
- Not required for spaces without skylights or that have loads <150W in toplit zones

**ADDITIONAL OPTIONS:**

- Room can be connected to nLight backbone to enable network control or time schedules (C405.2.2.1 - Time-Switch Controls), and also qualify for Enhanced Digital Lighting Controls (C406.4)
- HVAC control available through system-wide BACnet® interface option on the ECLYPSE controller
- Luminaires with wireless networked embedded controls from nLight with occupancy/daylighting sensor options available, please see the fixture specification sheet
- nLight wired or wireless networked control devices address the monitoring and configuration requirements of Luminaire Level Lighting Controls (LLLC) (C405.2.1, C405.2.4, C405.2.5)

**Note: Contact your local lighting agent for more information on luminaires with networked embedded controls from nLight. nLight wired or wireless networked control devices address the requirements of Luminaire Level Lighting Controls (LLLC), as specified in the IECC 2018 CODE.**

## Wireless Parking Garage

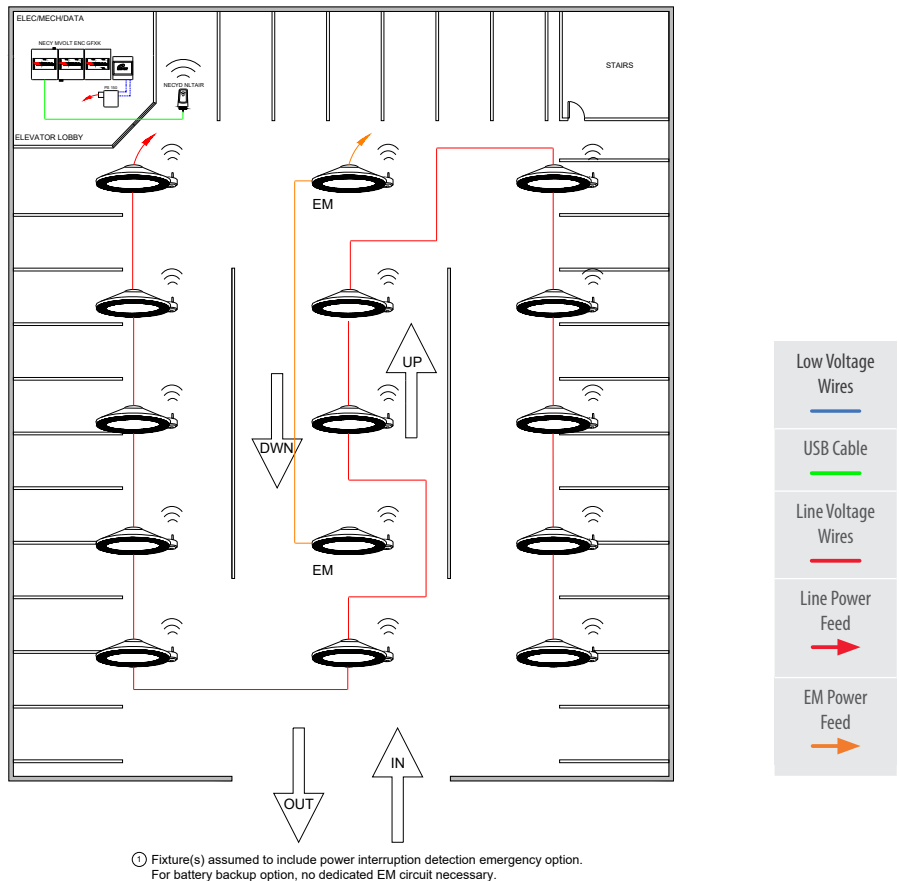

### Bill of Materials

Symbol	Qty	Product #	Description
	13	See Note	Canopy Luminaire with Wireless Networked Embedded Controls from nLight with Sensor Option
	2	See Note	Canopy Luminaire with Wireless Networked Embedded Controls from nLight with Sensor and Emergency Option
	1	nECY	nLight ECLYPSE Network System Controller
	1	nECYD NLTAIR G2	nLight AIR Adapter

#### / OPERATIONAL DETAILS:

##### Light Fixtures:

- All fixtures are dimmable
- All fixtures can be controlled together or independently
- Maximum level can be task tuned to any percentage via programming

##### Occupancy Control:

- Fixtures automatically go to full bright when occupied
- Fixtures automatically turn off or optionally can be configured to drop to low dim setting when space becomes vacant

##### Daylight Control:

- Daylight responsive controls lights to full off when adequate daylight present

#### / ADDITIONAL OPTIONS:

- Devices can be connected to nLight backbone to embedded network control or time schedules, including astronomical time schedules for shutoff (C405.2.6.2), lighting setback (C405.2.6.3), & exterior time-switch control (C405.2.6.4). GFXK option can be added to nLight ECLYPSE to provide manual override (C405.2.5).
- Luminaires with wireless networked embedded controls from nLight with occupancy/daylighting sensor options available, please see the fixture specification sheet
- nLight wired or wireless networked control devices address the monitoring and configuration requirements of Luminaire Level Lighting Controls (LLLC) (C405.2.1, C405.2.4, C405.2.5)

**Note: Contact your local lighting agent for more information on luminaires with networked embedded controls from nLight. nLight wired or wireless networked control devices address the requirements of Luminaire Level Lighting Controls (LLLC), as specified in the IECC 2018 CODE.**

## Wireless Site Lighting

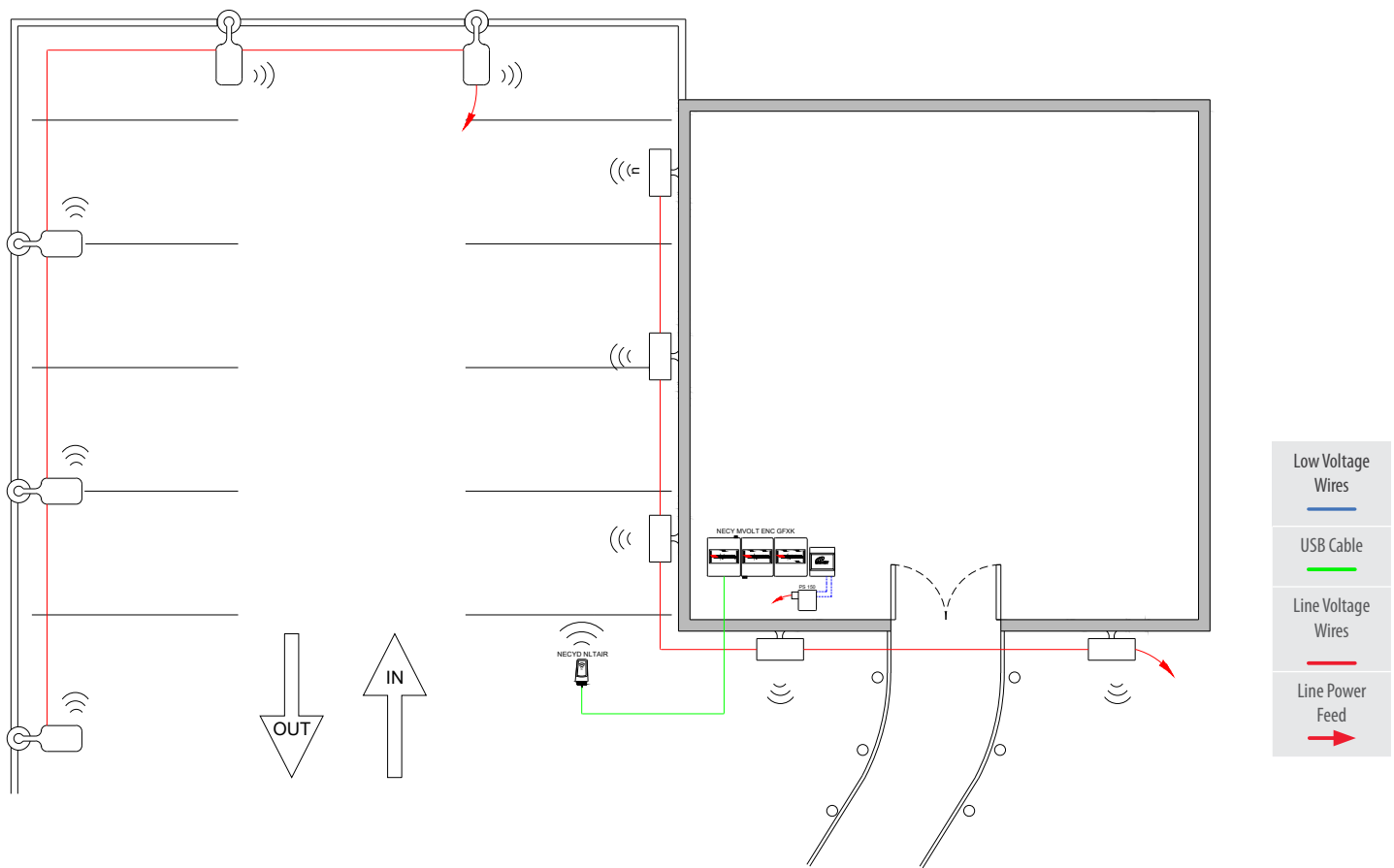

### Bill of Materials

Symbol	Qty	Product #	Description
	5	See Note	Area Luminaire with Wireless Networked Embedded Controls from nLight
	5	See Note	Wall Mount with Wireless Networked Embedded Controls from nLight
	1	nECY	nLight ECLYPSE Network System Controller
	1	nECYD NLTAIR G2	nLight AIR Adapter

#### OPERATIONAL DETAILS:

##### Light Fixtures:

- All fixtures are dimmable
- All fixtures can be controlled together or independently
- Maximum level can be task tuned to any percentage via programming

##### Occupancy Control:

- Fixtures automatically go to full bright when occupied
- Fixtures automatically turn off or optionally can be configured to drop to low dim setting when space becomes vacant

##### Daylight Control:

- Daylight responsive controls lights to full off when adequate daylight present



#### ADDITIONAL OPTIONS:

- Devices can be connected to nLight backbone to embedded network control or time schedules, including astronomical time schedules for shutoff (C405.2.6.2), lighting setback (C405.2.6.3), & exterior time-switch control (C405.2.6.4). GFXK option can be added to nLight ECLYPSE to provide manual override (C405.2.5).
- Luminaires with wireless networked embedded controls from nLight with occupancy/daylighting sensor options available, please see the fixture specification sheet
- nLight wired or wireless networked control devices address the monitoring and configuration requirements of Luminaire Level Lighting Controls (LLLC) (C405.2.1, C405.2.4, C405.2.5)

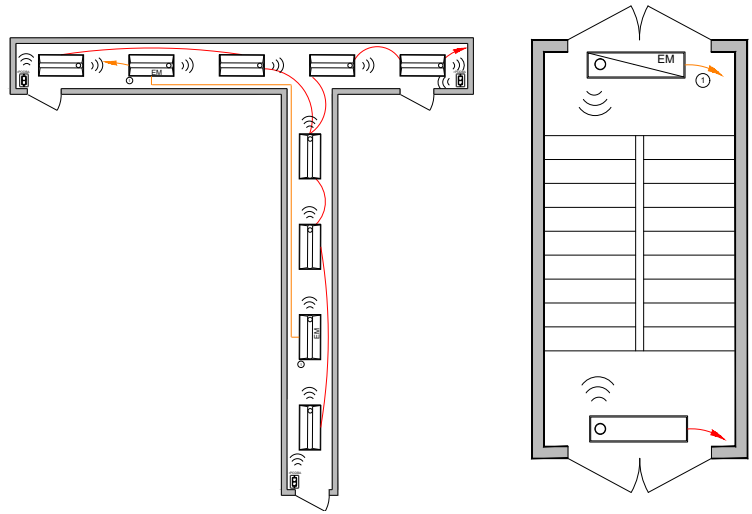
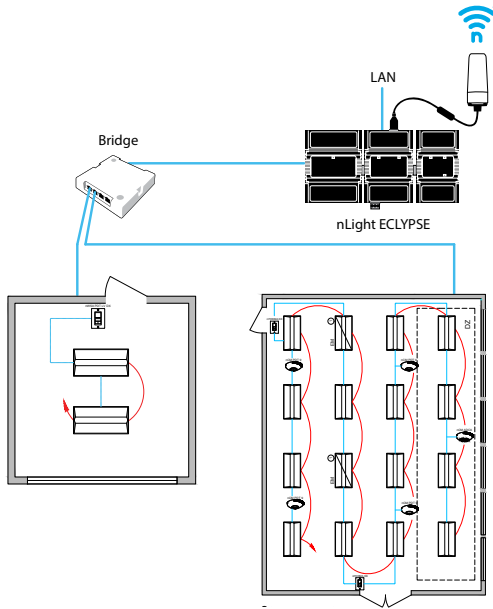
**Note:** Contact your local lighting agent for more information on luminaires with networked embedded controls from nLight. nLight wired or wireless networked control devices address the requirements of Luminaire Level Lighting Controls (LLLC), as specified in the IECC 2018 CODE.











**Bill of Materials**

Symbol	Qty	Product #	Description
	1	nBRG 8 KIT	8-Port Backbone Bridge
	1	nECY MVOLT ENC	nLight ECLYPSE Network System Controller and Optional BMS Interface
	1	nECYD NLTAIR G2	nLight AIR Adapter

**Programmable Time Clock Control:**

Although not pictured within each of the individual room design guides, each nLight controlled space can be connected via an nLight backbone to create a networked nLight lighting control system capable of meeting the requirements of IECC 2018 Provision C405.2.2.1, Time-Switch Controls. A networked system also enables astronomical time clock control.

Control Requirement		Code Provision	nLight Solution Details	
Manual Control (Local Switch)	C405.2.5	nLight WallPod devices provide a user with local control of lighting within an nLight controlled space. WallPods are available in multiple styles – each with varying features and user experiences.		
		<b>Push-Button WallPod</b>	<b>Graphic WallPod*</b>	
		<a href="#">nPODMA Series</a> <a href="#">rPODBA Series</a> 	<a href="#">nLight UNITOUCH Touchscreen Wall Switch</a> 	
Traditional tactile buttons and LED user feedback.	Full-color touch screen provides a sophisticated look and feel.			
Shut-Off Control Time-Switch Controls and Exterior Lighting Control (via System Controller)	C405.2.2.1 C405.2.6.2 C405.2.6.3 C405.2.6.4	Individual nLight control groups (i.e.: rooms) can be easily networked together across an entire building simply by connecting them into a “backbone” made up of one or more nLight bridge devices and/or nLight AIR adapters and an nLight ECLYPSE system controller. The system controller provides programmable time clock functionality for an nLight network as well as interfaces to the SensorView suite of web-based software applications (via an Ethernet LAN / WAN connection).		
		<b>Network System Controller</b>		
		<a href="#">Network System Controller</a> 		
Additional benefits of installing an nLight backbone include remote status monitoring, system-wide configuration changes, and BMS interface capability.				
Full Auto-Off via Occupancy Sensor	C405.2.1.1.1	nLight occupancy sensors utilize 100% digital passive infrared (PIR) detection, come in several mounting styles, and offer multiple coverage pattern options. Additionally, nLight sensors are available with patented Microphonics™ dual technology detection for rooms with obstructions. Configuring for full off vs. partial off control is done with system programming.		
Manual On, Auto-On <=50%, Full Automatic On	C405.2.1.1.2	<b>360° Occupancy Sensor</b>	<b>120° WideView Corner Sensor*</b>	
		<a href="#">nCM Series</a> <a href="#">rCMS Series</a> <a href="#">rCMSB Series</a> 	<a href="#">nWV Series</a> 	
		Surface mounts to ceiling tiles or sheetrock/plaster.	Directly mounts in corner or to ceiling via repositionable ceiling bracket.	
Light-Level Control Light-Reduction Controls	C405.2.2.2	<b>Acuity Brands Luminaires with Networked Embedded Controls from nLight</b>	<b>Dimming Relay Packs</b>	
			<a href="#">nPP16 Series</a> <a href="#">rPP20 Series</a> 	
		Acuity Brands offers a wide variety of LED fixtures with factory installed embedded controls from nLight that provide smooth continuous dimming.	nLight dimming relay enable control of any 0-10VDC dimmable LED luminaire.	
Daylight-Responsive Controls	C405.2.3.1 C405.2.3.2	nLight offers standalone daylight harvesting sensors as well as occupancy sensors with integrated daylight harvesting. Sensors are available in various housings and provide continuous dimming control of any/all luminaires with networked embedded controls from nLight or dimming relay packs, each capable of being its own daylight zone.		
		<b>Ceiling Mount Dimming Photocell</b>	<b>Recessed Mount Dimming Photocell*</b>	
		<a href="#">nCM Series</a> <a href="#">rCMSB Series</a> 	<a href="#">nRM Series</a> 	

\*Available with nLight Wired products only.

Note: This summary is for general information purposes only and is provided without any warranty as to accuracy, completeness, or otherwise. The user should read the applicable code sections for more complete and detailed descriptions of code requirements and exceptions and should consult with a professional engineering or other competent advisor before making any decision or taking any action based on this summary.

## 2018 IECC and Emergency Lighting

The nLight platform offers flexible, UL924 compliant control of emergency lighting. It addresses the needs of conventional projects that use extra wiring to charge battery packs inside of fixtures or to tell control devices to enter an emergency state when normal power is lost. Traditional lighting controls would make use of a shunt device in addition to a lighting control device (Figure 1). nLight consolidates the shunt device and lighting control device into a single digital device, which reduces installation and maximizes control (Figure 2). Wireless products also offer power interruption detection to initiate emergency control when normal power is lost. This modern method removes the need for extra wiring, further reducing the cost of installing emergency controls without sacrificing the intelligence and configurability that is expected from nLight devices (Figure 3).

IECC lighting controls requirement C405.2 (and subsection 405.2.5 for exterior lighting controls) provides exceptions for emergency and egress lighting, indicating that lighting controls are not required for the following types of lighting:

- Areas designated as security or emergency areas that are required to be continuously lighted.
- Interior exit stairways, interior exit ramps and exit passageways.
- Emergency egress lighting that is normally off.
- Lighting for covered vehicle entrances or exits from buildings or parking structures where required for safety, security or eye adaptation.

Generally speaking, lighting that is normally on during occupied periods, normally dimmed or off during unoccupied periods, and also used to provide for egress during emergency power conditions should be controlled in compliance with C405.2. nLight features various UL924 listed options that can be specified to provide both lighting control in compliance with IECC and emergency operation in compliance with locally enforced fire codes.

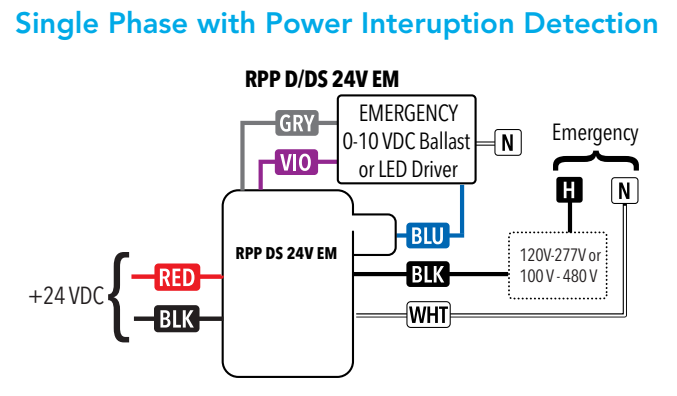
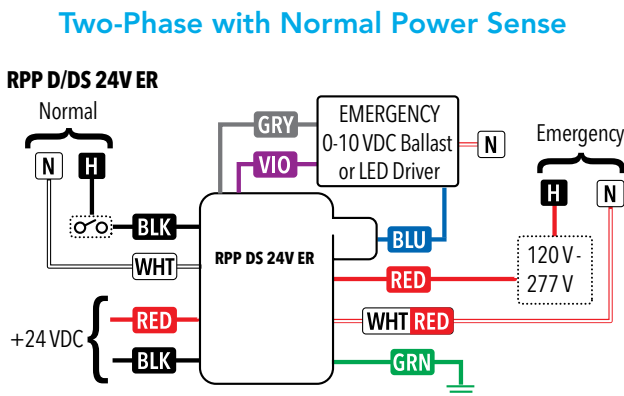
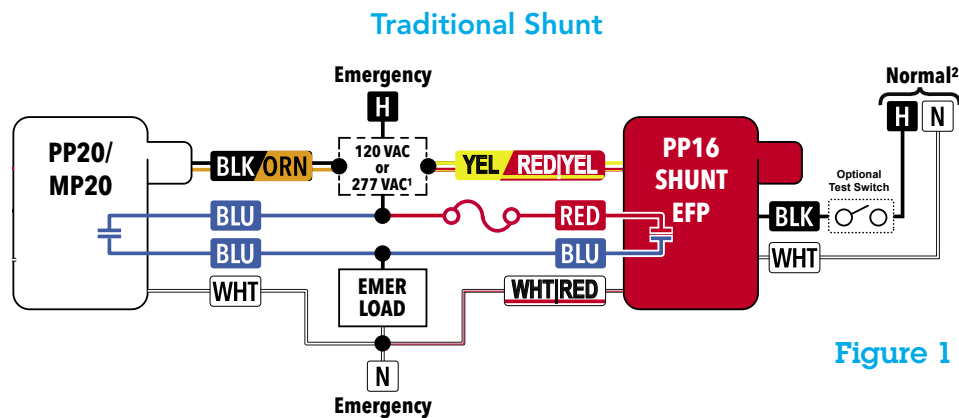

## Luminaires with Networked Embedded Controls from nLight

Acuity Brands offers the industry's broadest portfolio of controls embedded luminaires. Please scan the QR code to see the current luminaires with networked embedded controls from nLight.



Luminaires with Wireless Networked Embedded Controls from nLight



Luminaires with Wired Networked Embedded Controls from nLight

## Mobile Apps

Quick and Easy Lighting Configuration and Control In the Palm of Your Hand

### nLight Wired



#### nLight BLE Radio Module

nLight wired uses the nIO BT (Bluetooth® Low Energy radio module) to communicate with the nConfig app to modify the settings and operation of the devices in an nLight zone.

The Bluetooth® word mark and logos are registered trademarks owned by Bluetooth SIG, Inc. and any use of such marks by Acuity Brands Lighting is under license.

#### nConfig™

The nConfig mobile app is for nLight wired controls startups. It's a quick and easy alternative to SensorView software for smaller projects and simple programming.

### nLight AIR



#### CLAIRITY™ Pro

The CLAIRITY Pro mobile app allows you to start up, configure and troubleshoot nLight AIR wireless controls from a compatible smartphone or tablet.



# Additional Resources

## Acuity Controls Typical Layout Drawings

<https://www.acuitybrands.com/resources/tools-and-documents/typicals>

## IECC

<http://www.iccsafe.org/>

### Use the Following Sections of the IECC 2018 Code as Reference:

- Section C405.2.1.1.1 – Full Auto-Off via Occupancy Sensor
- Section C405.2.1.1.2 – Manual-On or Partial-On
- Section C405.2.1.1.2 – Full Automatic On
- Section C405.2.1.3 – Local Switch
- Section C405.2.2.1 – Programmable Timeclock
- Section C405.2.3 – Daylight-Responsive Controls
- Section C405.2.5 – Manual Lighting Reduction
- Section C405.2.6 – Exterior Lighting Controls
- Section C406.4 – Enhanced Digital Lighting Controls

## Explore Acuity Academy

Acuity Academy provides educational resources for individuals wanting to expand their lighting, controls and building management technical knowledge. On Acuity Academy, you can register for instructor-led classes, take e-learning courses or watch videos and recorded content. <https://www.acuitybrands.com/resources/training-and-education>

## nLight Lighting Controls Platform Page

[www.nlightcontrols.com](http://www.nlightcontrols.com)



**A+ Certified** solutions from Acuity Brands help you quickly and confidently select and implement lighting systems that are both compatible and consistent.

For lighting applications, A+ means verified consistent performance, visual appearance and system interoperability of all luminaires and controls within the certified solutions. For lighting professionals it means confidence that all parts of the lighting system will work together and meet common Acuity Brands specifications.

Go to [www.acuitybrands.com/solutions/a-certified](http://www.acuitybrands.com/solutions/a-certified) or contact your local Acuity Brands representative for more information.

The Bluetooth® word mark and logos are registered trademarks owned by Bluetooth SIG, Inc. and any use of such marks by Acuity Brands Lighting is under license.